



SAFETY VALVES SERIES

SMU-7000





PRESSURE-RELIEF VALVES

SMU-7000

SERIES SMU-7000

This range of spring loaded conventional Pressure Relief Valves is for installation of any SECTION VIII application and are available from pressure range of 0.3 Bar to 414 Bar and for pressure ratings up to 2500#. Sizes from 1" D 2" to 8" T 12" in different material of construction depending on the application.

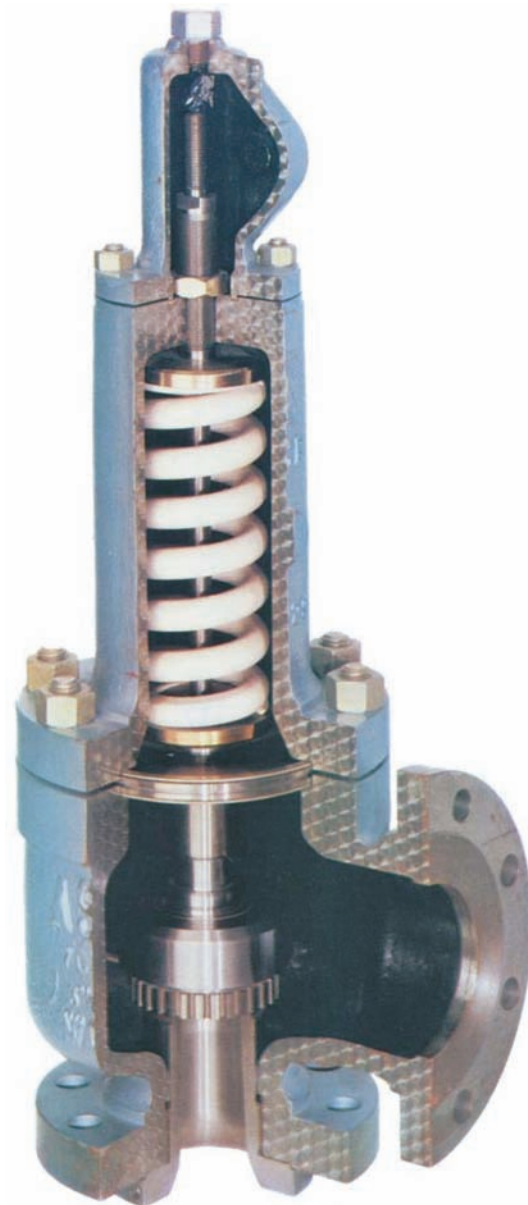



Main Features

Flanged, Spring loaded, Direct acting, Full nozzle pressure relief valves.

- Media** : Gas, Steam and Liquid.
- Orifices** : From "D" to "T" acc. To API 526; intermediate orifices (K2, P2, Q2, R2) and orifices up to 1520.5 cm² available.
- Set pressure range** : From 0.3 bar to 414 bar.
- Temperature range** : From -267o C to 715o C.
- Overpressure** : Gas and Steam 3% or 10%, Liquid 10%.
- Blowdown** : Gas and Steam 5% to 7%.
- Materials** : Carbon Steel, Alloy Steel, Hastelloy, Monel and other materials upon request.
- Options** : Bellows, Flushing nozzle, Lifting lever, Test gag, Finned bonnet, Limit switch, Resilient or Hardened seat.

Sizes/Pressure Classes

Size inlet & outlet: from NPS 1 to NPS 8 & from NPS 2 to NPS 12
Rating: up to ASME 2500. Special solution ASME 4500 and up to API 10k available.

Design Codes & Product Standards

EN ISO 4126-1, EN 764-7, EN 12516, EN 1092, API 520, API 521, API 526, API 527, ASME B16.34, ASME B16.5, ASME Sect.VIII

Homologations & Approvals

CE marking (97/23/CE PED and 94/9/CE ATEX), AQSISQ (China), Gost (Russia), SVTI ASIT (Switzerland).

SERIES SMU-7000

BASIC SPECIFICATIONS HIGHLIGHTS

The series SMU-7000 consists of spring loaded, full nozzle, full lift safety relief valves.

Calculation and performance are in accordance to the most important European and international standards such as PED 97/23/CE, ASME VIII, EN ISO 4126, API 520, Stoomwezen, SVDB, GOST, AQSISQ, etc.

Body thickness complies to ASME B16.34 standard.

The series SMU-7000 can satisfy, among the others, the requirements of the standard API 526.

Flanges comply to ASME B16.5.

All pressurized components are hydraulically tested.

Seat tightness test is performed at 95% of the set pressure allowing operating pressure very close to the set-pressure of the safety valve.

Standardization of the components of the valve reduces the spare parts number.

The high flow coefficient allows the most economical sizing of the valve.

INTRODUCTORY NOTES

CONNECTIONS

Flanged connections indicated for each orifice in the selection tables on pages 11 and 12, are in accordance to ASME B16.5.

Connections are also furnished in accordance to ISO, EN, UNI, DIN, BS etc.

DISCHARGE COEFFICIENTS

Valves series SMU-7000 have been tested and certified with GAS in accordance with EN ISO 4126-1, and the results are the following:

- $K_d=0.959$ with 3% over pressure
- $K_d=0.968$ with 10% over pressure

Valves with trim for LIQUID and GAS series SMU-7000 /LIQ have been homologated, and the results are the following:

- Liquid, $K_d=0.735$ with 10% over pressure
- Liquid, $K_d=0.745$ with 25% over pressure
- Gas, $K_d=0.918$ with 10% over pressure

Discharge coefficient value in accordance with ASME VIII and with EN ISO 4126-1 shall be reduced by 10% ($K_{dr}=K_d*0.9$).

BLOWDOWN

UKL AST declares a blowdown value between 5% and 7% of the set pressure. This value shall anyway not be lower than 0,25 bar and depends on the operating conditions, the type of fluid and the position of the blowdown ring which is positioned in the shop in order to obtain good performance.



INTRODUCTORY NOTES

COLD DIFFERENTIAL TEST PRESSURE TOLERANCE

The tolerances on the cold differential test pressure are the following:

- Up to 3,7 bar ±4% or ±0,04 bar whichever is greater
- 3,7 to 21 bar ±3% or ±0,15 bar whichever is greater
- over 21 bar ±1% or 0,7 bar whichever is greater

MINIMUM COLD DIFFERENTIAL TEST PRESSURE (SPRING SETTING)

The minimum cold differential test pressure is shown in the following table.

For conventional valves with special construction, the minimum cold differential test pressure can be reduced to 0,4 bar.

Orifice	D	E	F	G	H	J	K	K2	L	M	N	P	P2	Q	Q2	R	R2	T
	bar																	
Without Bellows	0,4																	
With Bellows	1,5	1,5	1,5	1,5	1,4	1,3	1,2	1,1	1,1	1	1	1	0,9	0,9	0,8	0,8	0,7	0,6

SEAT TIGHTNESS (Nozzle - Disc)

UKL AST uses more severe limits than suggested in the API-527 standards: test pressure is 95% of the cold differential test pressure (instead of 90%) while the bubbles per minute limit is placed at a value a lot lower than mentioned in the standards.

COLD DIFFERENTIAL TEST PRESSURE RANGE (SPRING SETTING)

The cold differential test pressure can be modified from the value setted in the factory and without changing the spring, within the following range:

- up to 17,9 bar ±10%
- over 17,9 bar ±1,8 bar or ±5% whichever is greater.

COLD DIFFERENTIAL TEST PRESSURE (AT AMBIENT TEMPERATURE) FOR VALVES WORKING AT HIGH TEMPERATURE

Safety relief valves are bench setted at ambient temperature. Relieving temperatures higher than 212°F cause a reduction of the spring rate and an expansion of the body and bonnet, as a result the force of the spring on the disc will decrease.

The cold differential test pressure at ambient temperature should therefore be higher than the set pressure at the discharge temperature.

Corrections to be made must be evaluated each time depending also on the type of inspection to be done on the valve; the following table shows the corrections suggested by: **UKL AST**

Relieving Temperature		Cold Differential Test Pressure Increase %
°C	°F	
-238 ÷ 100	-396 ÷ 212	0%
101 ÷ 230	214 ÷ 446	1,5%
231 ÷ 480	447 ÷ 896	3%
481 ÷ 538	898 ÷ 1000	3,5%

BALANCED PRESSURE RELIEF VALVES (with bellows or piston)

Series SMU-7000 valves can be provided with balancing and separation bellows.

This accessory is used when:

- a) There is a variable superimposed back pressure;
- b) The built-up back pressure during discharge is greater than 10% of the set pressure;
- c) It is needed to separate the disc-guide, the spring and all the parts inside the bonnet from the process fluid when the latter is corrosive, viscous, could crystallize or leave deposits and incrustations.

The bellows is designed to effort the greatest possible flexibility, greatest mechanical strength and the best possible balancing effect.

In order to avoid the effects of great built-up back pressure and if the media can be discharged into the atmosphere, the valve can be equipped with balancing piston.

Balancing bellows and piston can be coupled in order to grant a higher functional reliability of the valve in case of damaging of the bellows.

CLASSIFICATION

The selection of UKL AST safety relief valves is simplified by an alphanumeric coding system by which each kind of valve materials and accessories may be exactly identified:

- SMU-7000 series basic model (see page 10)
- W tungsten steel valve spring (see page 10)



- CM *Tungsten steel spring and Materials to table, page 10*
- (S4) *Completely in AISI 304*
- (LCC) *Materials to table, page 10*
- (LCB) *Materials to table, page 10*
- (SS2) (SS4) *Materials to table, pag. 10*

ACCESSORIES

- /B *Bellows*
- /La *Plain lever (no stuffing box)*
- /L *Packed lever (stuffing box)*
- /T *Test gag*
- /R *Heating jacket*
- /O *O-ring (soft seated disc)*
- /D *Finned bonnet extension (high temperature duty)*
- /U *Valve seat injection nozzles*
- /LIQ *Special trim for liquids.*

Example: SMU-7000-W/BLT

- Valve construction of materials as per list, page 10
- For utilization in the temperature range 232,5 - 426°C
- Tungsten steel valve spring - balancing bellows packed lever and test gag supplied.

15	STEM RETAINER
*16	BODY GASKETS
*17	CAP GASKET
18	SPRING
19	DRAIN PLUG
20	BODY STUDS
21	BODY NUTS
22	CAP STUDS
23	CAP NUTS
24	DISC BALL
*25	BELLOWS
26	EXTENSION
27	CAP
28	CAP PLUG
29	BELLOWS PROTECTOR
*31	O-RING(SOFT SEATED DISC)
32	SPECIAL NUT
33	GASKET
34	PACKING RING
35	NUT
36	LEVER SHAFT
37	GLAND HOUSING
38	LEVER CAP
39	LEVER
40	PACKING FOLLOWER
41	PACKING LOCKNUT

* Recommended spare parts

SERIES SMU-7000 VALVES

1	BODY
2	BONNET
*3	NOZZLE
4	DISC HOLDER
*5	DISC
6	BLOWDOWN RING
7	GUIDE
8	STEM
9	SPRING ADJ. SCREW
10	LOCKNUT
*11	SPRING WASHERS
12	ADJ. RING SCREW
13	PIN
*14	DISC RETAINER

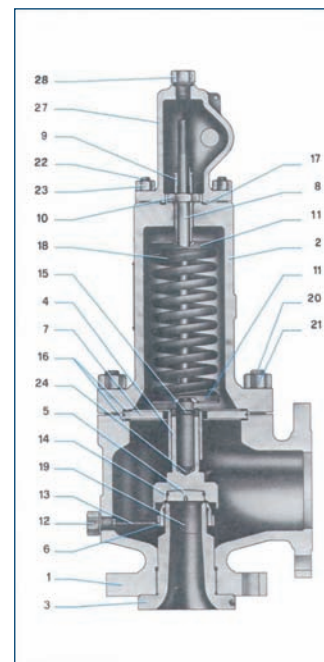

Conventional Valve

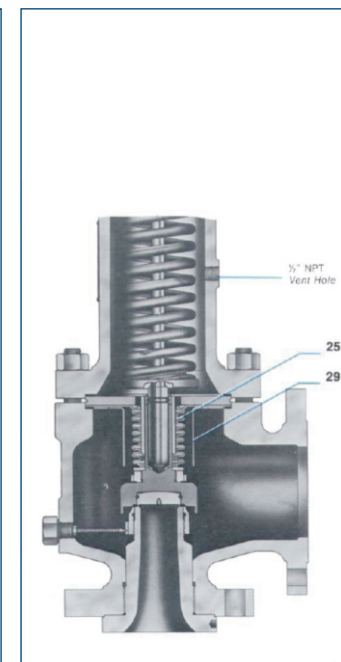

Bellows Valve



SERIES SMU-7000 VALVES

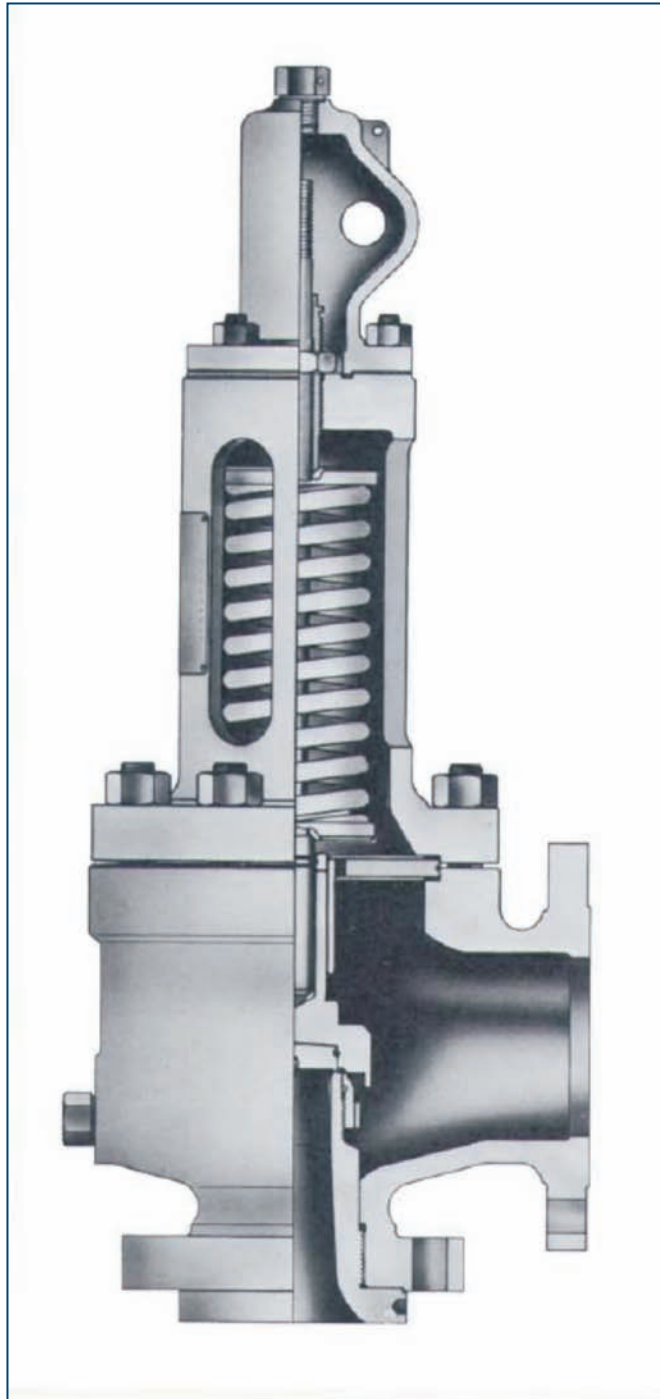

Open Bonnet Valve Temperature max 350°C With Carbon Steel Spring

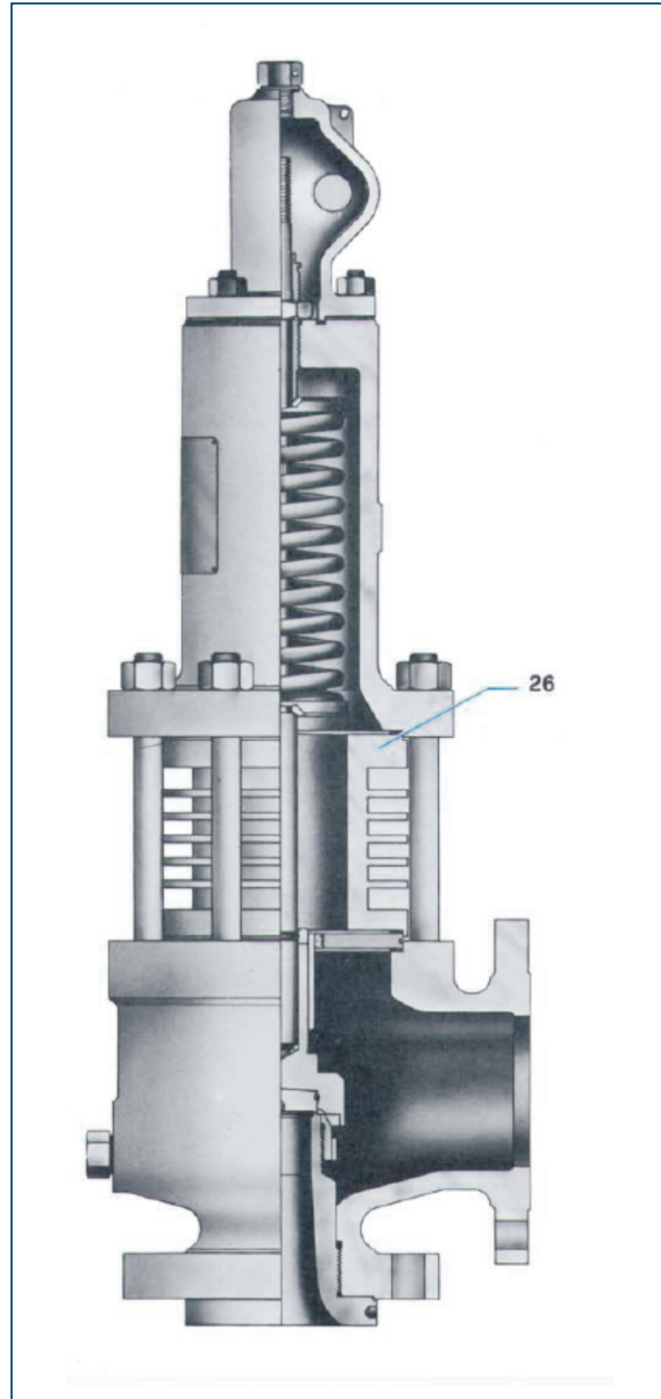

Closed Bonnet Valve with Extension To use temperature range from 426 °C to 538 °C



SERIES SMU-7000 VALVES

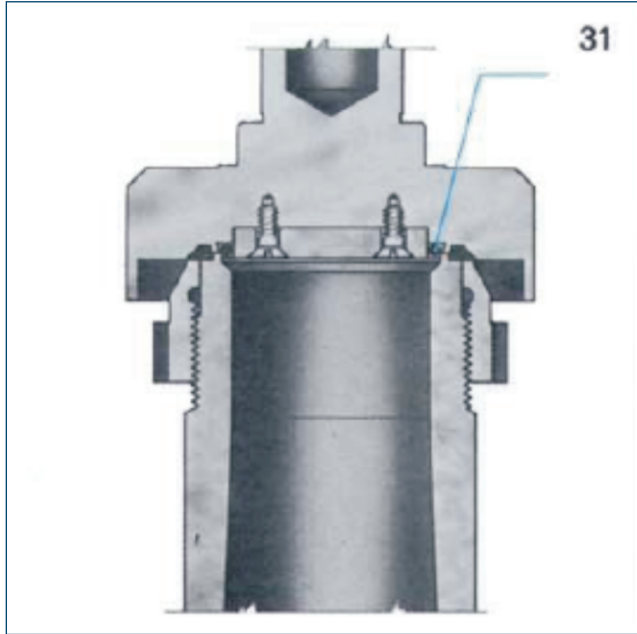

Soft. seated disc (viton; teflon; kalrez) for low pressures (max 19 bar) and temperature (-29°C + 200°C)

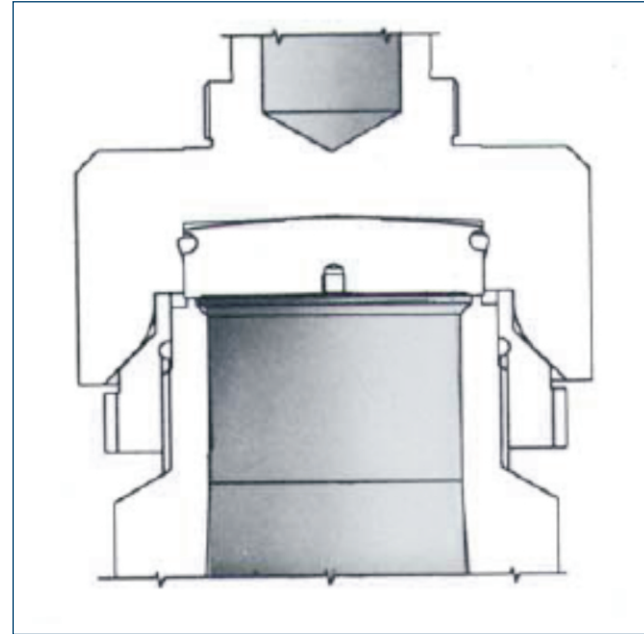

Special trim for liquids(series 100-SV/LIQ)

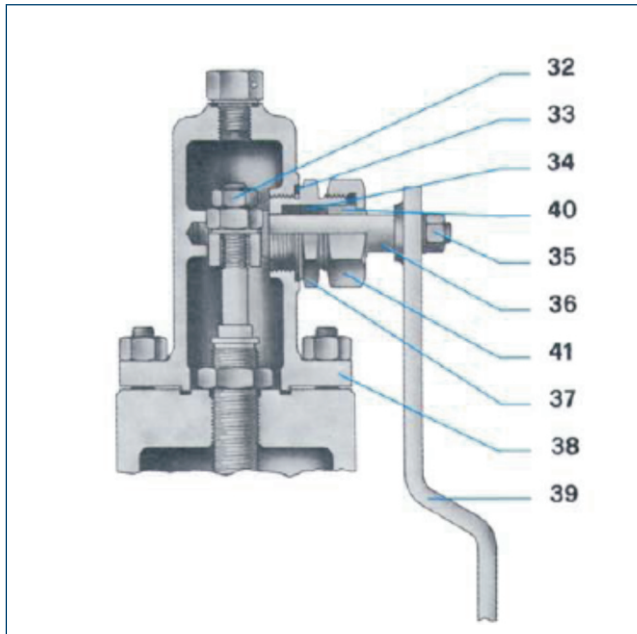

Cap with packed or plain lever

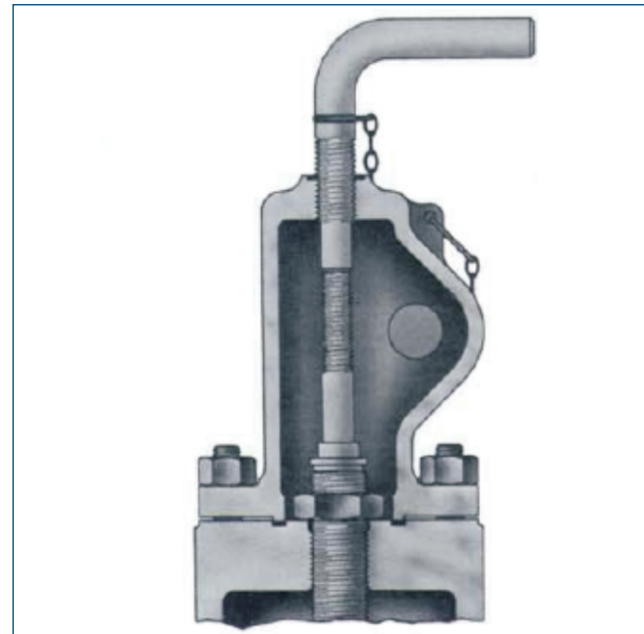

Cap with test gag



ACCESSORIES

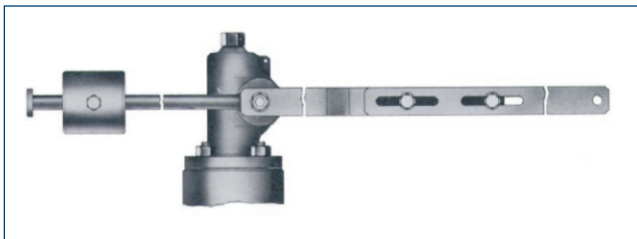

Type "R" counter weighted lever

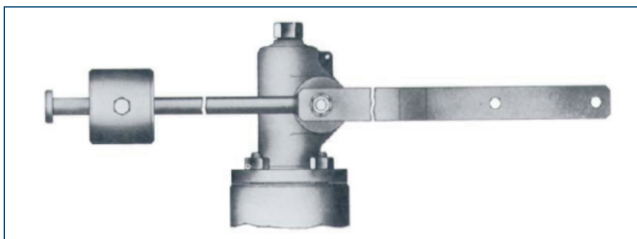

Type "L" counter weighted lever

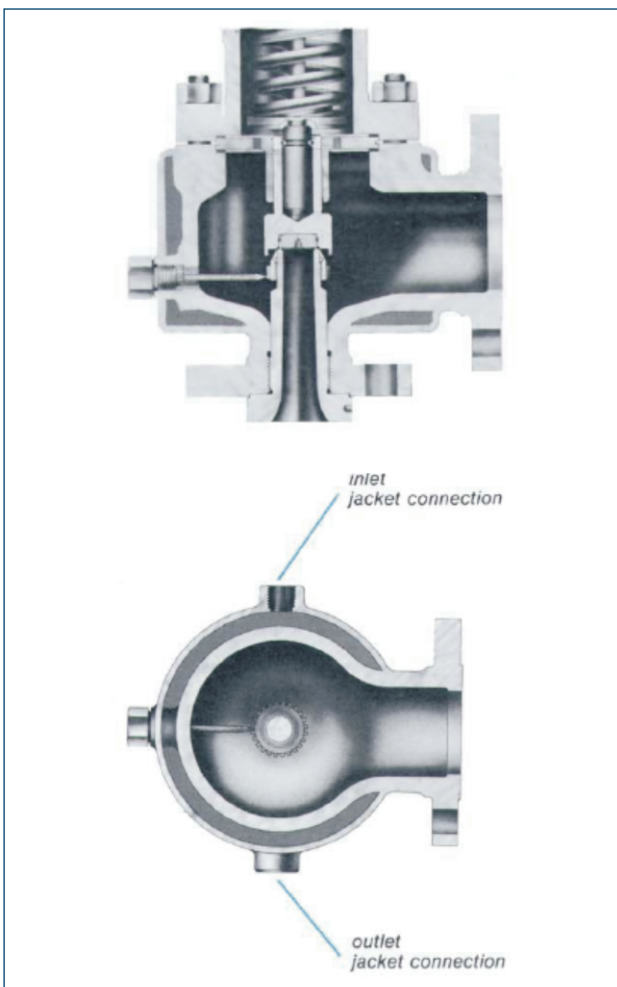

Jacketed Body Valves Series SMU-7000

<i>Valve Orifice</i>	<i>Jacket Connections</i>
<i>D E F G H J K L</i>	<i>3/8"</i>
<i>K L M N P</i>	<i>1/2 "</i>
<i>Q R T</i>	<i>3/4"</i>

BODY VALVE HEATING JACKET

(Jacket limiting pressure : 10kg/cm2 limiting temperature 185°C.)



Suggested use of hardened seats

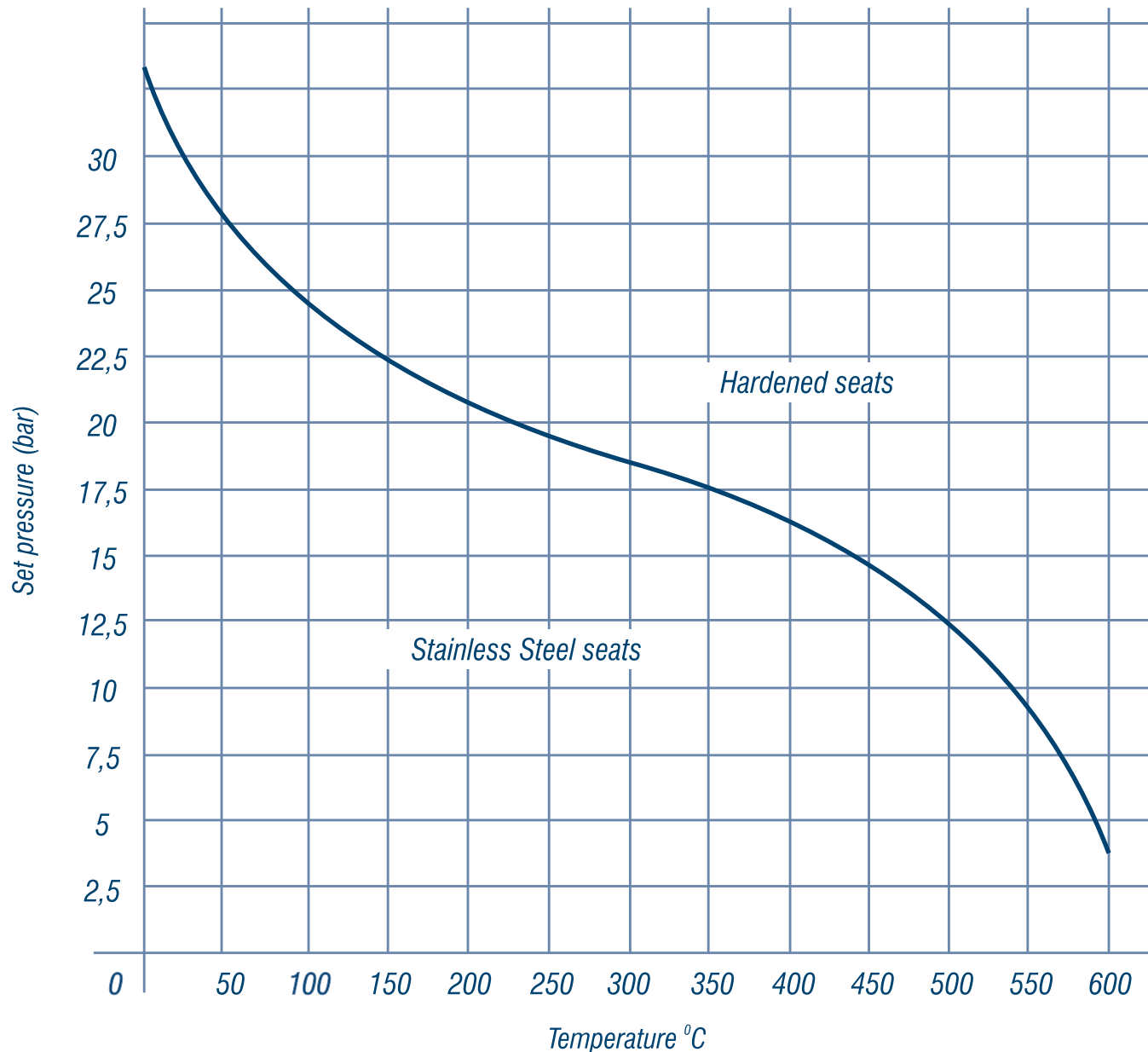

SERIES SMU-7000 VALVES

Nozzle-disc seats manufactured by **UKL AST** are of the metal to metal type.

They can be supplied hardened (with stellite or made in 17-4PH) or resilient (with o-ring). The most frequent cases in which these constructions are requested are:

1) hardened when the media is dirty, may crystallize or contain solids

2) hardened for medium and high pressure depending on the temperature, see following diagram

3) resilient when requested by client

UKL AST will suggest the best solution for each operating condition.



SERIES SMU-7000 VALVES

STANDARD MATERIALS FOR NORMAL AND HIGH TEMPERATURE			
PART NAME	ALLOWABLE RANGE TEMPERATURE		
	NORMAL & HIGH TEMP. -29-232°C	NORMAL & HIGH TEMP. 232-426°C	NORMAL & HIGH TEMP. 426-538°C
	SMU-7000-STD	SU-100-W	SMU-7000-
BODY	A216 WCB	A 216 WCB	A217 WC6
BONNET	A216 WCB	A 216 WCB	A217 WC6
NOZZLE	A479 316 A351 CF8M	A479 316 A351 CF8M	A479 316 A351 CF8M
DISC HOLDER	UNS S31600 A351CF8	UNS S30400 A351 CF8	UNS S30400 A351 CF8
DISC	A479 316	A479 316	A479 316
ADJUSTING RING	UNS S30400 A 351 CF8	UNS S30400 A351 CF8	UNS S30400 A351 CF8
GUIDE	UNS S41000	UNS S41000	UNS S41000
GASKET	GRAPHITE	GRAPHITE	GRAPHITE
SPRING	ALLOY STEEL	ALLOY STEEL	TUNGSTEN STEEL
STUD	A193 B7	A193 B7	A 193B16
NUT	A 194 2H	A194 2H	A194 4
BELLOWS	UNS S31603	UNS S31603	UNS S31603
CAP	A216 WCB A105	A 216 WCB A 105	A216 WCB A 105

On request the valves can be supplied partially or completely in Aluminium

STANDARD MATERIALS FOR NORMAL AND LOW TEMPERATURE				Std. Material for Corrosive Appl	
PART NAME	ALLOWABLE RANGE TEMPERATURE			<i>Internal parts except Spring</i>	<i>Complete</i>
	-267 to -101,5°C	-101 to -45,5°C	-45 to -29,5°C		
	SMU-7000(S4)	SMU-7000(LCC)	SMU-7000(LCB)	SMU-7000-SS2	SMU-7000-
BODY	A351 CF8	A352 LCC	A352 LCB	A 216 WCB	A351 CF8M
BONNET	A351 CF8	A352 LCC	A352 LCB	A 216 WCB	A351 CF8M
NOZZLE	A479 316 A351 CF8M	A479 316 A351 CF8M	A479 316 A351 CF8M	A479 316 A351 CF8M	A479 316 A351 CF8M
DISC HOLDER	UNS S31600 A351CF8	UNS S31600 A351CF8	UNS S31600 A351CF8	UNS S30400 A351 CF8	UNS S31600 A351CF8M
DISC	A479 316	A479 316	A479 316	A479 316	A479 316
ADJUSTING RING	UNS S30400 A 351 CF8	UNS S30400 A 351 CF8	UNS S30400 A 351 CF8	UNS S30400 A351 CF8	UNS S31600 A351CF8M
GUIDE	UNS S30400	UNS S31600	UNS S31600	UNS S31600	UNS S31600
GASKET	GRAPHITE	GRAPHITE	GRAPHITE	GRAPHITE	GRAPHITE
SPRING	UNS S31600	ALLOY STEEL	ALLOY STEEL	ALLOY STEEL	UNS S31600
STUD	A193 B8(cl. 1)	A320 L7	A320 L7	A 193 B7	A193 B8M(cl 1)
NUT	A194 8	A194 4	A194 4	A194 2H	A194 8M
BELLOWS	UNS S31603	UNS S31603	UNS S31603	UNS S31603	UNS S31603
CAP	A352 LCC A 350LF2	A352 LCC A 350LF2	A352 LCC A 350LF2	A216 WCB A 105	A351 CF8M UNS S31600

On request the valves can be supplied partially or completely in Aluminium



PRESSURE AND TEMPERATURE LIMITS (standard construction)

ORIF cm ² sq.in	SIZE Inlet x Outlet inch	RATING (ANSI) Inlet x Outlet	INLET									OUTLET	
			Max. Set Pressure (bar)									Max.pressure bar	
			Temperature (°C)									Without Bellows	With Bellows
			-267 -101,5	-101 -46,1	-46 -29,1	-29 38	232	426	426	538			
D 0,785 0,121	1x2	150x150	19,0	19,0	18,3	19,7	12,8	5,5	–	–	19,7	15,9	
	1x2	300x150	49,6	49,6	47,9	51,0	42,4	28,3	35,2	15,5	19,7	15,9	
	1x2	600x150	99,3	99,3	95,8	102,0	85,1	56,9	70,0	30,7	19,7	15,9	
	1 ½ x2	900x300	148,9	148,9	143,7	153,0	127,2	85,1	105,1	46,2	41,4	34,5	
	1 ½ x2	1500x300	248,2	248,2	239,2	255,4	212,3	142,0	175,1	76,9	41,4	34,5	
	1 ½ x3	2500x300	275,8	275	398,8	413,7	354,0	236,5	291,6	128,2	51,0	34,5	
E 1,389 0,215	1x2	150x150	19,0	19,0	18,3	19,7	12,8	5,5	–	–	19,7	15,9	
	1x2	300x150	49,6	49,60	47,9	51,0	42,4	28,3	35,2	15,5	19,7	15,9	
	1x2	600x150	99,3	99,3	95,8	102,0	85,1	56,9	70,0	30,7	19,7	15,9	
	1 ½ x2	900x300	148,9	148,9	143,7	153,0	127,2	85,1	105,1	46,2	41,4	34,5	
	1 ½ x2	1500x300	248,2	248,2	239,2	255,4	212,3	142,0	175,1	76,9	41,4	34,5	
	1 ½ x3	2500x300	275,8	275,8	398,8	413,7	354,0	236,5	291,6	128,2	51,0	34,5	
F 2,164 0,335	1 ½ x2	150x150	19,0	19,0	18,3	19,7	12,8	5,5	–	–	19,7	15,9	
	1 ½ x2	300x150	49,6	49,6	47,9	51,0	42,4	28,3	35,2	15,5	19,7	15,9	
	1 ½ x2 (a)	600x150	99,3	99,3	95,8	102,0	85,1	56,9	70,0	30,7	19,7	15,9	
	1 ½ x3	900x300	148,9	148,9	143,7	153,0	127,2	85,1	105,1	46,2	51,0	34,5	
	1 ½ x3	1500x300	151,7	234,9	239,2	255,4	212,3	142,0	175,1	76,9	51,0	34,5	
	1 ½ x3	2500x300	234,4	234,4	344,7	344,7	344,7	236,5	291,6	128,2	51,0	34,5	
G 3,530 0,547	1 ½ x3	150x150	19,0	19,0	18,3	19,7	12,8	5,5	–	–	19,7	15,9	
	1 ½ x3 (b)	300/600x150	49,6	49,6	47,9	51,0	42,4	28,3	35,2	15,5	19,7	15,9	
	1 ½ x3	300x150	49,6	49,6	47,9	51,0	42,4	28,3	35,2	15,5	19,7	15,9	
	1 ½ x3	600x150	99,3	99,3	95,8	102,0	85,1	56,9	70,0	30,7	19,7	15,9	
	1 ½ x3	900x300	148,9	148,9	143,7	153,0	127,2	85,9	105,1	46,2	51,0	34,5	
	2x3	1500x300	168,9	179,2	239,2	255,4	212,3	85,1	175,1	76,9	51,0	34,5	
	2x3	2500x300	179,2	179,2	255,4	255,4	255,4	142,0	255,4	128,2	51,0	34,5	
H 5,515 0,854	1 ½ x3	150x150	19,0	19,0	18,3	19,7	12,8	236,5	–	–	19,7	15,9	
	1 ½ x3 (b)	300/600x150	26,9	26,9	26,9	26,9	26,9	5,5	26,9	15,5	19,7	15,9	
	2x3 (a)	300/600x150	26,9	49,9	47,9	51,0	42,4	26,9	35,2	15,5	19,7	15,9	
	2x3	600x150	49,6	99,3	95,8	102,0	85,1	28,3	56,2	30,7	19,7	15,9	
	2x3	900x150	99,3	110,3	143,7	153,0	127,2	56,9	84,5	46,2	19,7	15,9	
	2x3 (a)	1500x300	102,4	110,3	189,6	189,6	189,6	85,1	140,6	76,9	51,0	28,6	
J 9,079 1,407	2x3	150x150	110,3	19,0	18,3	19,7	12,8	142,0	–	–	19,7	15,9	
	2x3	300x150	19,0	26,2	26,2	26,2	26,2	5,5	26,2	15,5	19,7	15,9	
	3x4 (a)	300x150	26,2	49,6	47,9	51,0	42,4	26,2	35,2	15,5	19,7	15,9	
	3x4	300x150	34,5	49,6	47,9	51,0	42,4	28,3	35,2	15,5	19,7	15,9	
	3x4	600x150	34,5	55,2	95,8	102,0	85,1	28,3	56,2	30,7	19,7	15,9	
	3x4	900x150	55,2	55,2	143,7	153,0	127,2	56,9	84,5	46,2	19,7	15,9	
K 12,946 2,006	3x4	150x150	19,0	19,0	18,3	19,7	12,8	142,0	–	–	19,7	10,3	
	3x4	300x150	36,2	41,4	47,9	51,0	42,4	5,5	35,2	15,5	19,7	10,3	
	3x4	600x150	41,4	41,4	95,8	102,0	85,4	28,3	56,2	30,7	19,7	10,3	
	3x4 (a)	900x150	41,4	41,4	127,2	127,2	127,2	56,9	84,5	46,2	19,7	13,8	
	3x6	900x150	51,7	51,7	143,7	153,1	127,2	85,1	84,5	46,2	19,7	13,8	
	3x6	1500x300	51,7	51,7	153,1	153,1	153,1	142,0	140,6	76,9	41,4	13,8	
Std. materials		Body	CF8	LC3	LCB	WCB			WC6				
		Spring	Stainless Steel		Carbon Steel			Tungsten Steel					

(a) Non API526 center to face dimension

(b) Class 600 not included in API526



ORIF cm ² sq.in	SIZE InletxOutlet inch	RATING (ANSI) InletxOutlet	INLET								OUTLET	
			Max. Set Pressure (bar)								Max. Pressure bar	
			Temperature (°C)								Without Bellows	With Bellows
			-267 -101,5	-101 -46,1	-46 -29,1	-29 38	232	426	426	538		
K2 16,619 2,575	3x4	150x150	19,0	19,0	18,3	19,7	12,8	5,5	--	--	19,7	10,3
	3x4	300x150	36,2	41,4	47,9	51,0	42,4	28,3	35,2	15,5	19,7	10,3
	3x4	600x150	41,4	41,4	95,8	102,0	85,1	56,9	56,9	30,7	19,7	10,3
	3x4	900x150	41,4	41,4	102,0	102,0	102,0	85,1	84,5	46,2	19,7	13,8
	3x6	900x150	51,7	51,7	143,7	153,1	127,2	85,1	84,5	46,2	19,7	13,8
	3x6	1500x300	51,7	51,7	153,1	153,1	153,1	142,0	140,6	76,9	41,4	13,8
L 20,109 3,116	3x4	150x150	19,0	19,0	18,3	19,7	12,8	5,5	--	--	19,7	10,3
	3x4	300x150	25,5	25,5	25,5	25,5	25,5	25,5	25,5	15,5	19,7	10,3
	4x6	300x150	36,9	36,9	47,9	51,0	42,4	28,3	35,2	15,5	19,7	10,3
	4x6	600x150	36,9	36,9	69,0	69,0	69,0	56,9	69,0	30,7	19,7	10,3
	4x6(a)	900x150	48,3	48,3	103,4	103,4	103,4	85,1	103,4	46,2	19,7	13,8
	4x6(a)	1500x150	48,3	48,3	103,4	103,4	103,4	103,4	103,4	76,9	19,7	13,8
M 25,339 3,927	4x6	150x150	19,0	19,0	18,3	19,7	12,8	5,5	--	--	19,7	5,5
	4x6	300x150	36,2	36,2	47,9	51,0	42,4	28,3	35,2	15,5	19,7	11,0
	4x6	600x150	41,4	41,4	75,8	75,8	75,8	56,9	70,0	30,7	19,7	11,0
	4x6(a)	900x150	41,4	41,4	75,8	75,8	75,8	75,8	75,8	46,2	19,7	11,0
N 30,581 4,740	4x6	150x150	19,0	19,0	18,3	19,7	12,8	5,5	--	--	19,7	5,5
	4x6	300x150	31,0	31,0	47,9	51,0	42,4	28,3	35,2	15,5	19,7	11,0
	4x6(a)	600x150	34,5	34,5	69,0	69,0	69,0	56,9	69,0	30,7	19,7	11,0
	4x6(a)	900x150	34,5	34,5	69,0	69,0	69,0	69,0	69,0	46,2	19,7	11,0
P 45,007 6,976	4x6	150x150	12,1	12,1	18,3	19,7	12,8	5,5	--	--	19,7	5,5
	4x6	300x150	20,7	20,7	36,2	36,2	36,2	28,3	35,2	15,5	19,7	11,0
	4x6	300x150	20,7	20,7	36,2	36,2	36,2	28,3	35,2	15,5	19,7	11,0
	4x6	600x150	33,1	33,1	69,0	69,0	69,0	56,9	69,0	30,7	19,7	11,0
	4x6	900x150	33,1	33,1	69,0	69,0	69,0	69,0	69,0	46,2	19,7	11,0
P2 63,617 9,861	6x8	150x150	13,9	13,9	18,3	19,7	12,8	5,5	--	--	9,7	5,5
	6x8	300x150	21,1	21,1	27,6	27,6	27,6	27,6	27,6	15,5	9,7	9,7
	6x8	600x150	25,3	25,3	55,2	55,2	55,2	55,2	55,2	30,7	9,7	9,7
Q 77,913 12,076	6x8	150x150	11,4	11,4	11,4	11,4	11,4	5,2	--	--	7,9	4,8
	6x8	300x150	17,2	17,2	20,7	20,7	20,7	20,7	20,7	11,8	7,9	7,9
	6x8	600x150	17,2	17,2	20,7	20,7	20,7	20,7	20,7	20,7	7,9	7,9
	6x8	600x150	20,7	20,7	41,4	41,4	41,4	41,4	41,4	30,7	7,9	7,9
Q2 95,379 14,783	6x8	150x150	7,6	7,6	9,0	9,0	9,0	5,5	--	--	4,5	4,5
	6x8	300x150	10,5	10,5	13,8	13,8	13,8	13,8	13,8	9,0	4,5	4,5
	6x10	300x150	17,2	17,2	20,7	20,7	20,7	20,7	20,7	11,8	6,9	6,9
	6x10	600x150	20,7	20,7	31,0	31,0	31,0	31,0	31,0	24,5	6,9	6,9
R 112,663 17,462	6x8	150x150	3,8	3,8	6,9	6,9	6,9	5,5	--	--	4,1	4,1
	6x8	300x150	3,8	3,8	6,9	6,9	6,9	6,9	6,9	6,9	4,1	4,1
	6x10	300x150	7,6	7,6	11,8	11,8	11,8	11,8	11,8	11,8	6,9	6,9
	6x10	300x150	10,3	10,3	15,9	15,9	15,9	15,9	15,9	11,8	6,9	6,9
	6x10	600x150	13,8	13,8	20,7	20,7	20,7	20,7	20,7	20,7	6,9	6,9
R2 148,058 22,949	8x10	150x150	3,8	3,8	5,6	5,6	5,6	5,5	--	--	3,1	3,1
	8x10	300x150	7,6	7,6	20,7	20,7	20,7	20,7	20,7	15,5	6,9	6,9
T 183,281 28,408	8x10	150x150	3,4	3,4	4,5	4,5	4,5	4,5	--	--	2,1	2,1
	8x10	300x150	4,5	4,5	11,8	11,8	11,8	11,8	11,8	11,8	6,9	6,9
	8x10	300x150	7,6	7,6	20,7	20,7	20,7	20,7	20,7	15,5	6,9	6,9
	8x12	300x150	7,6	7,6	20,7	20,7	20,7	20,7	20,7	15,5	6,9	6,9
Std. materials	Body	CF8	LC3	LCB	WCB				WC6			
	Spring	Stainless Steel		Carbon Steel				Tungsten Steel				



D	ORIFICE	$0,785 \text{ cm}^2$ $0,121 \text{ in}^2$
---	---------	--

SELECTION CHART
PRESSURE-TEMPERATURE LIMITS (ACCORDING TO ANSI B16.34 AND API 526)

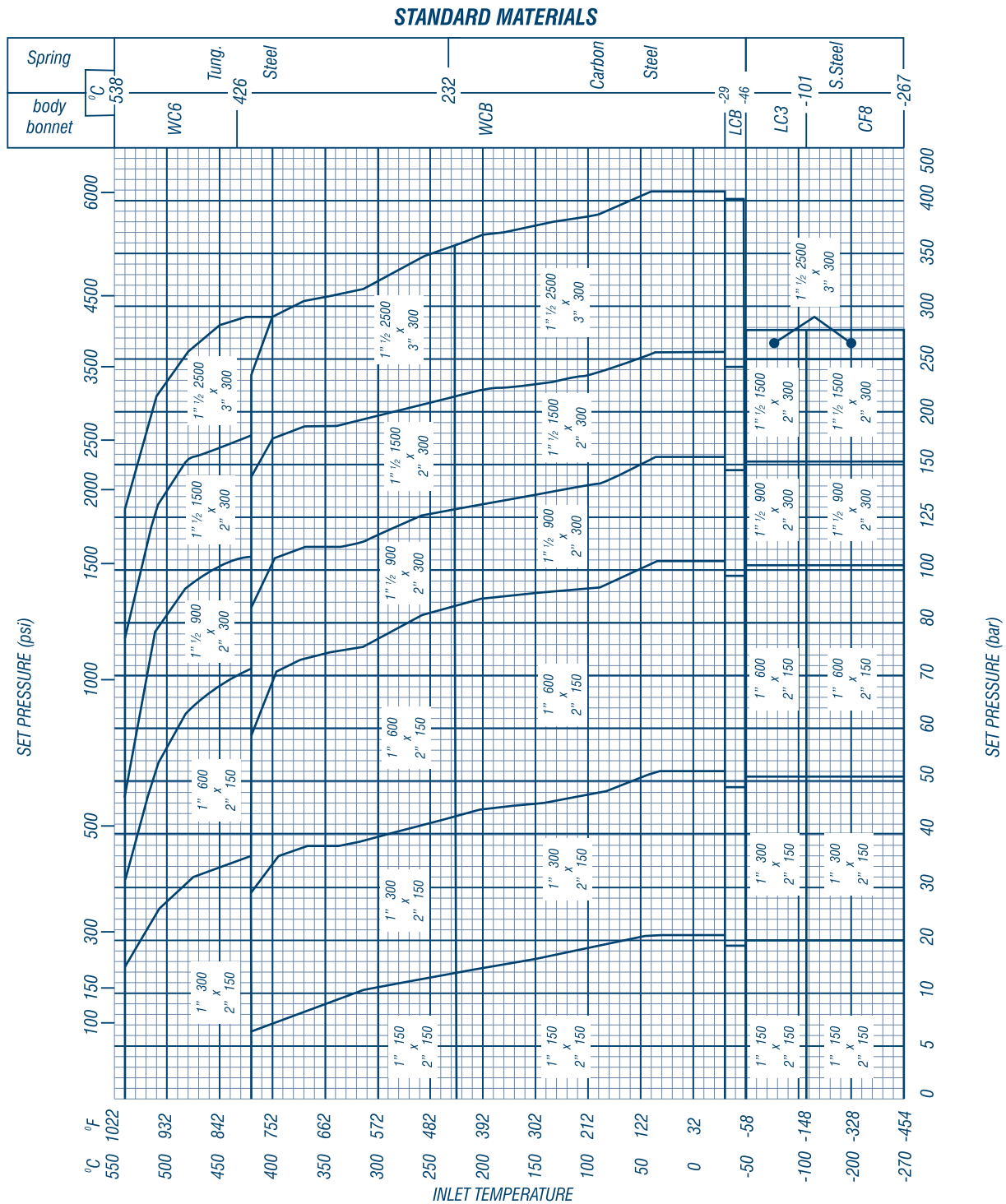



F	ORIFICE	$2,164 \text{ cm}^2$ $0,335 \text{ in}^2$
---	---------	--

SELECTION CHART
PRESSURE-TEMPERATURE LIMITS (ACCORDING TO ANSI B16.34 AND API 526)

STANDARD MATERIALS

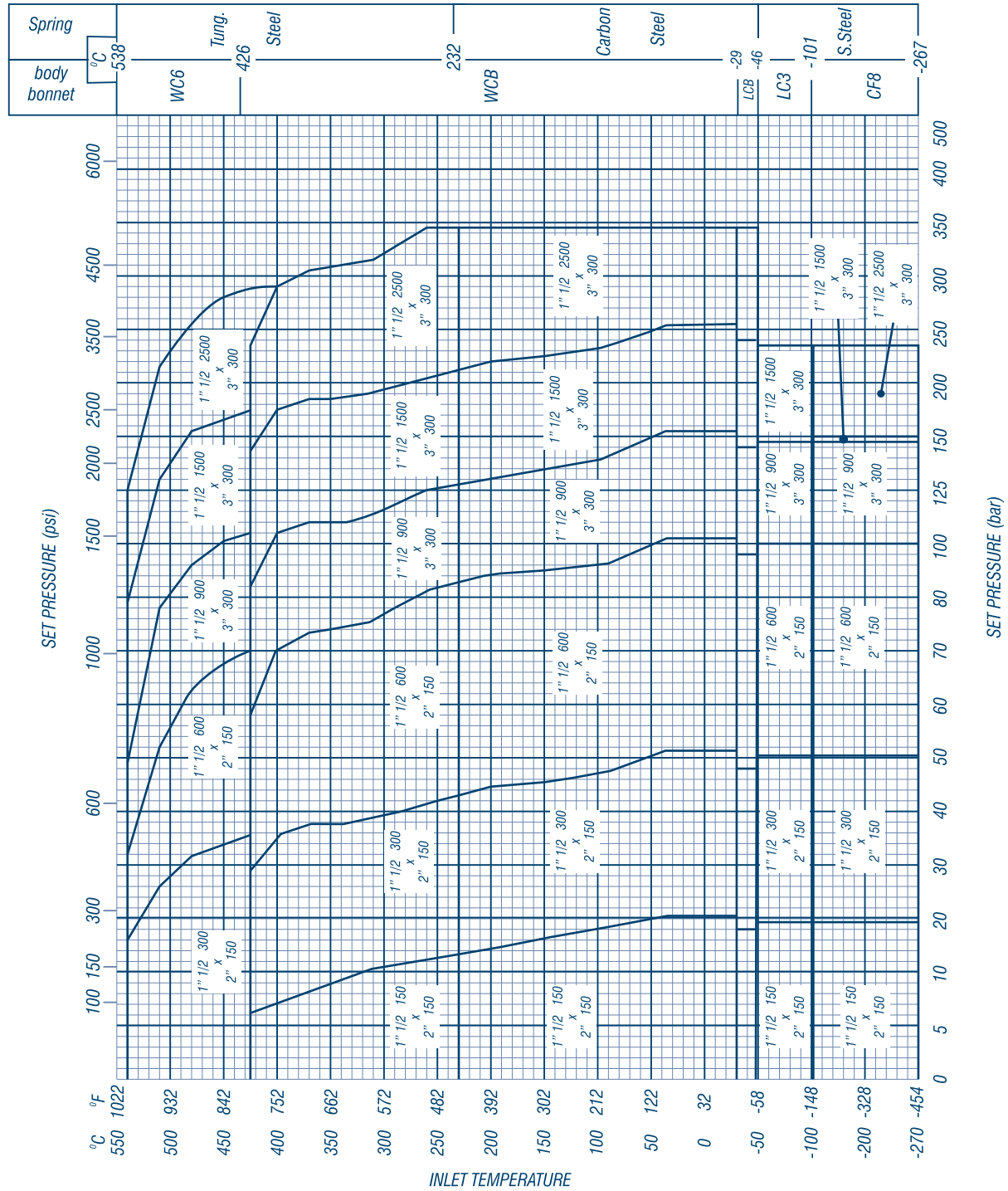



G	ORIFICE	3,530 cm² 0,547 in²
---	---------	--

SELECTION CHART
PRESSURE-TEMPERATURE LIMITS (ACCORDING TO ANSI B16.34 AND API 526)

STANDARD MATERIALS

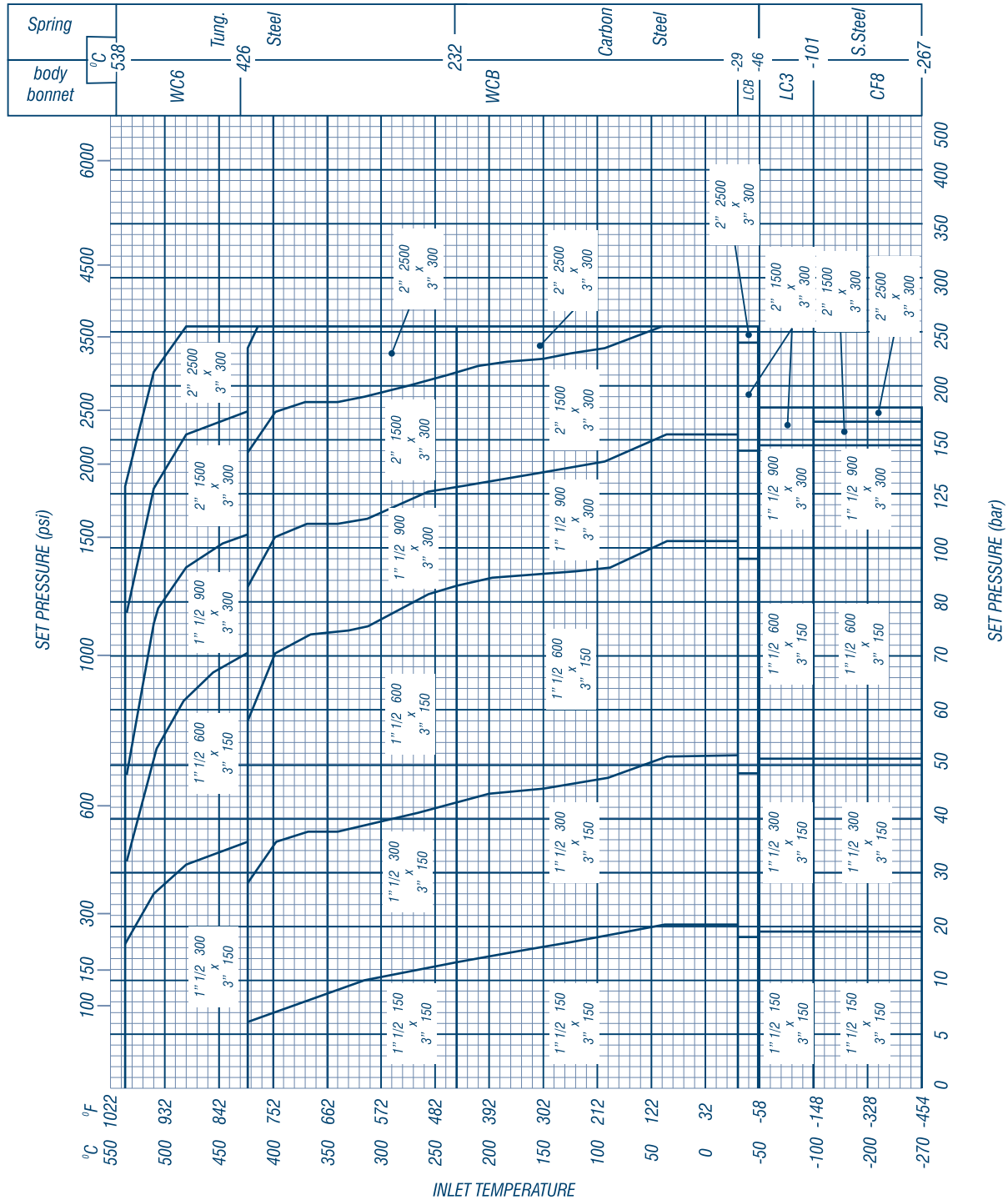



H	ORIFICE	5,515 cm² 0,854 in²
---	---------	--

SELECTION CHART
PRESSURE-TEMPERATURE LIMITS (ACCORDING TO ANSI B16.34 AND API 526)

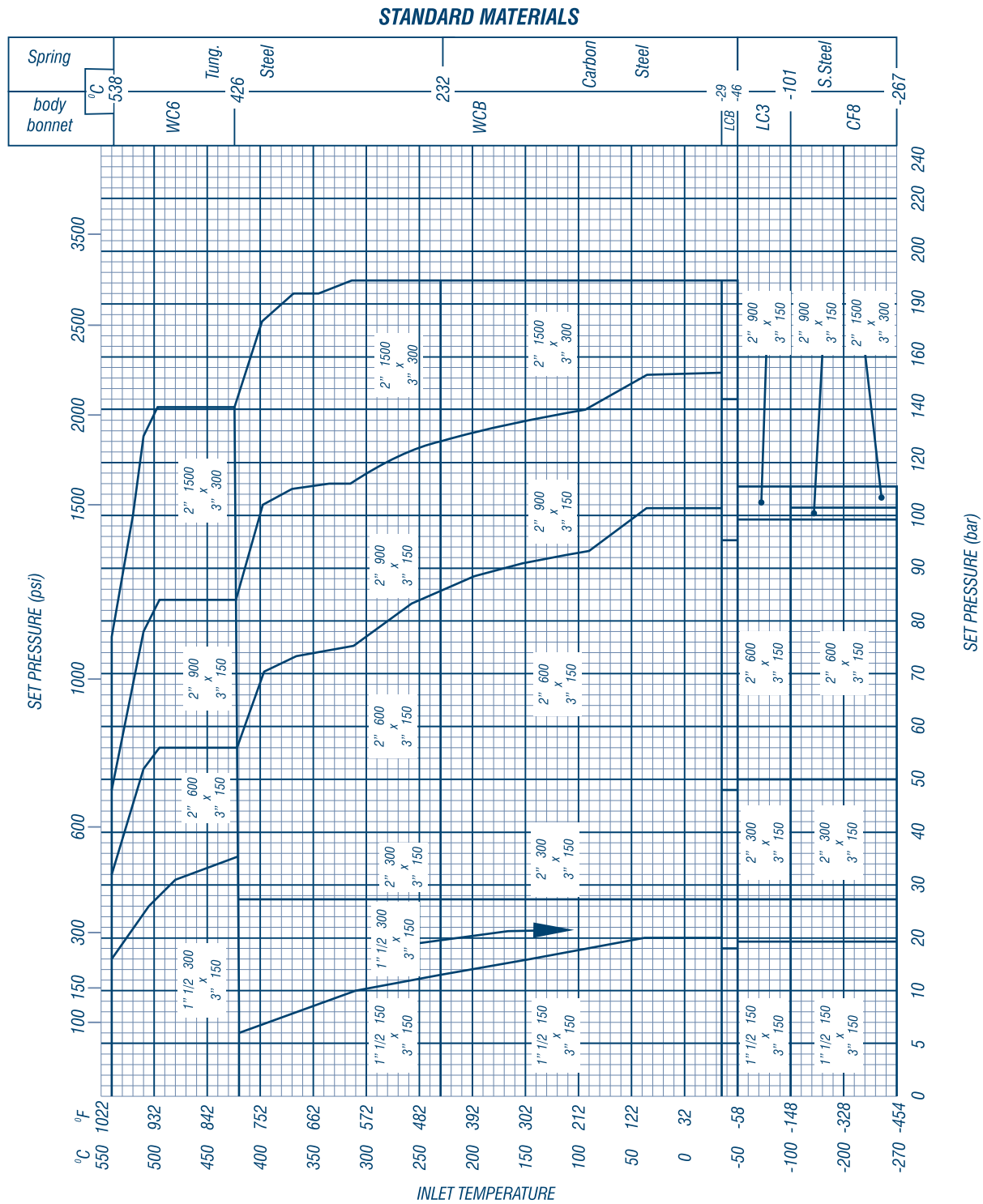



J	ORIFICE	9,079 cm² 1,407 in²
----------	----------------	--

SELECTION CHART
PRESSURE-TEMPERATURE LIMITS (ACCORDING TO ANSI B16.34 AND API 526)

STANDARD MATERIALS

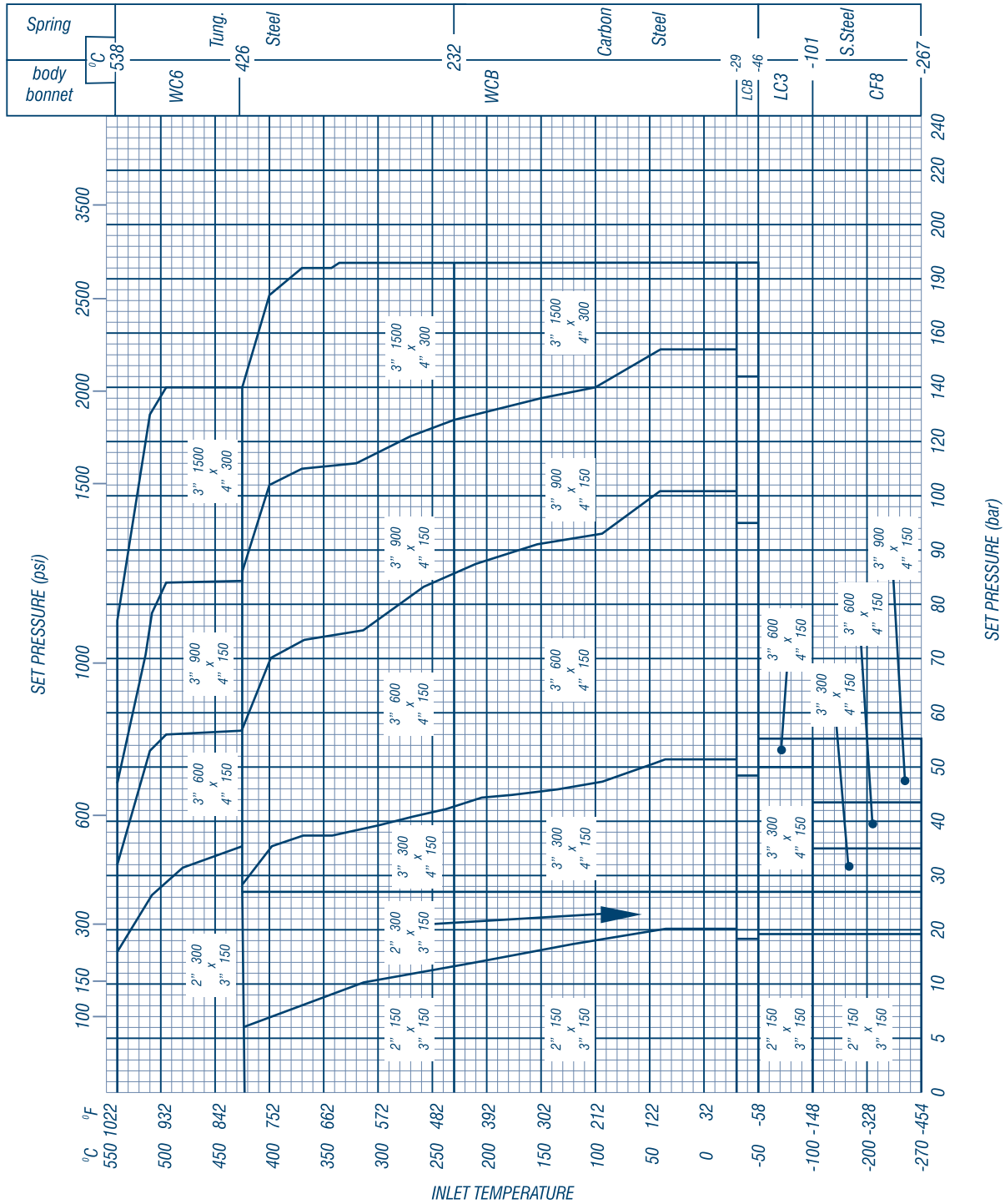



K₂	ORIFICE	16,619 cm² 2,575 in²
----------------------	----------------	---

SELECTION CHART
PRESSURE-TEMPERATURE LIMITS (ACCORDING TO ANSI B16.34 AND API 526)

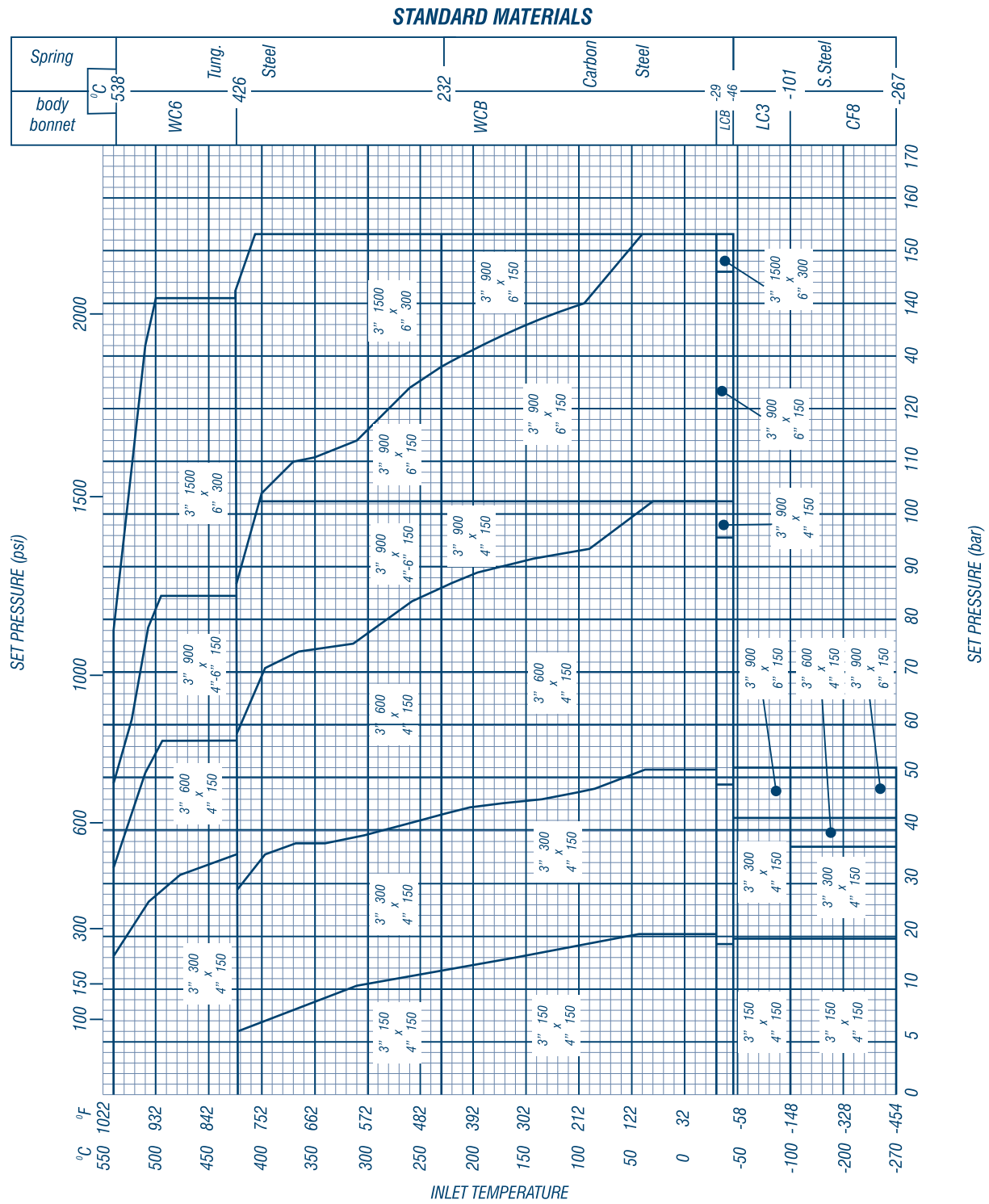



L	ORIFICE	20,109 cm² 3,116 in²
---	---------	---

SELECTION CHART
PRESSURE-TEMPERATURE LIMITS (ACCORDING TO ANSI B16.34 AND API 526)

STANDARD MATERIALS

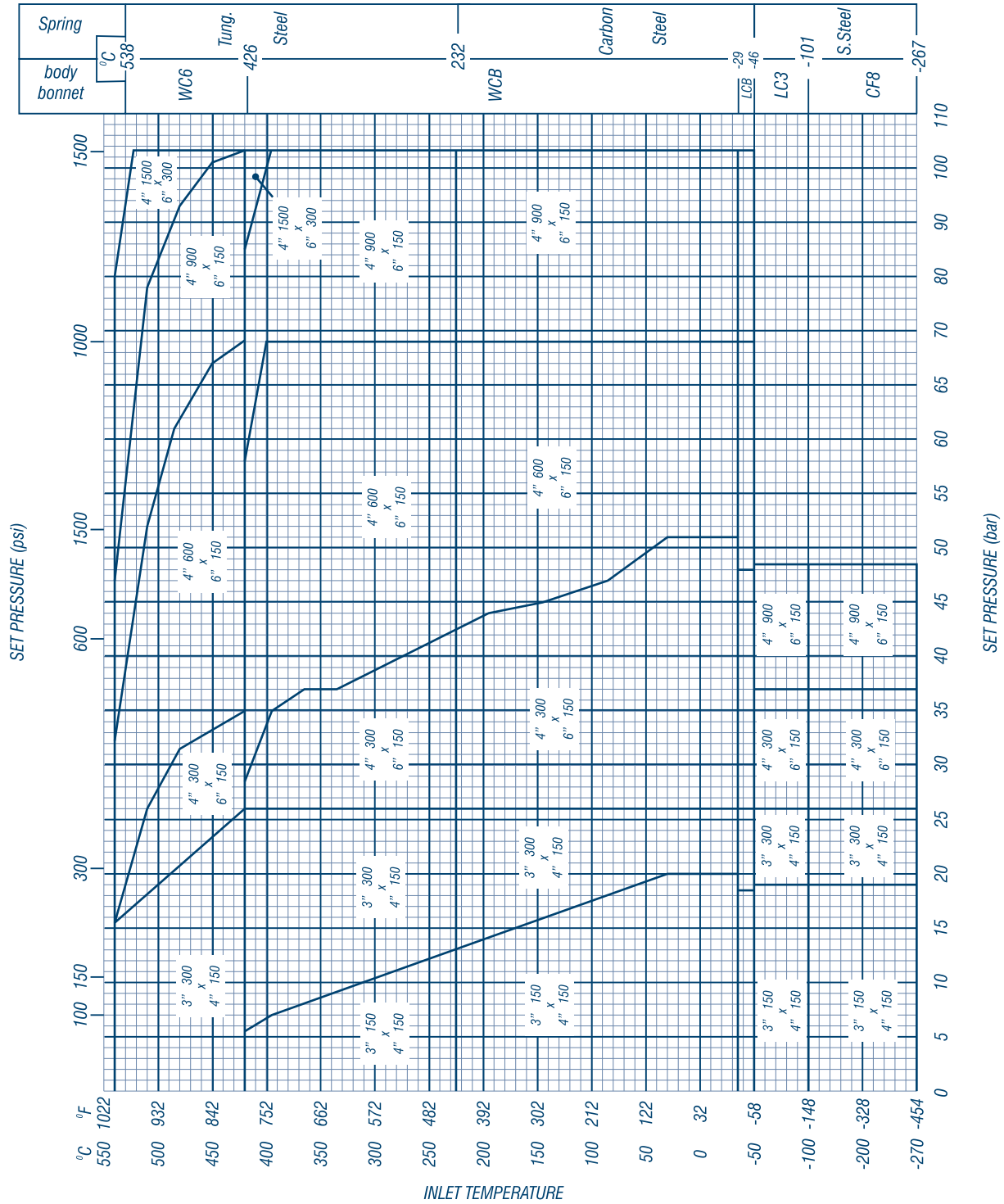



M	ORIFICE	25,339 cm² 3927 in²
----------	----------------	--

SELECTION CHART
PRESSURE-TEMPERATURE LIMITS (ACCORDING TO ANSI B16.34 AND API 526)

STANDARD MATERIALS

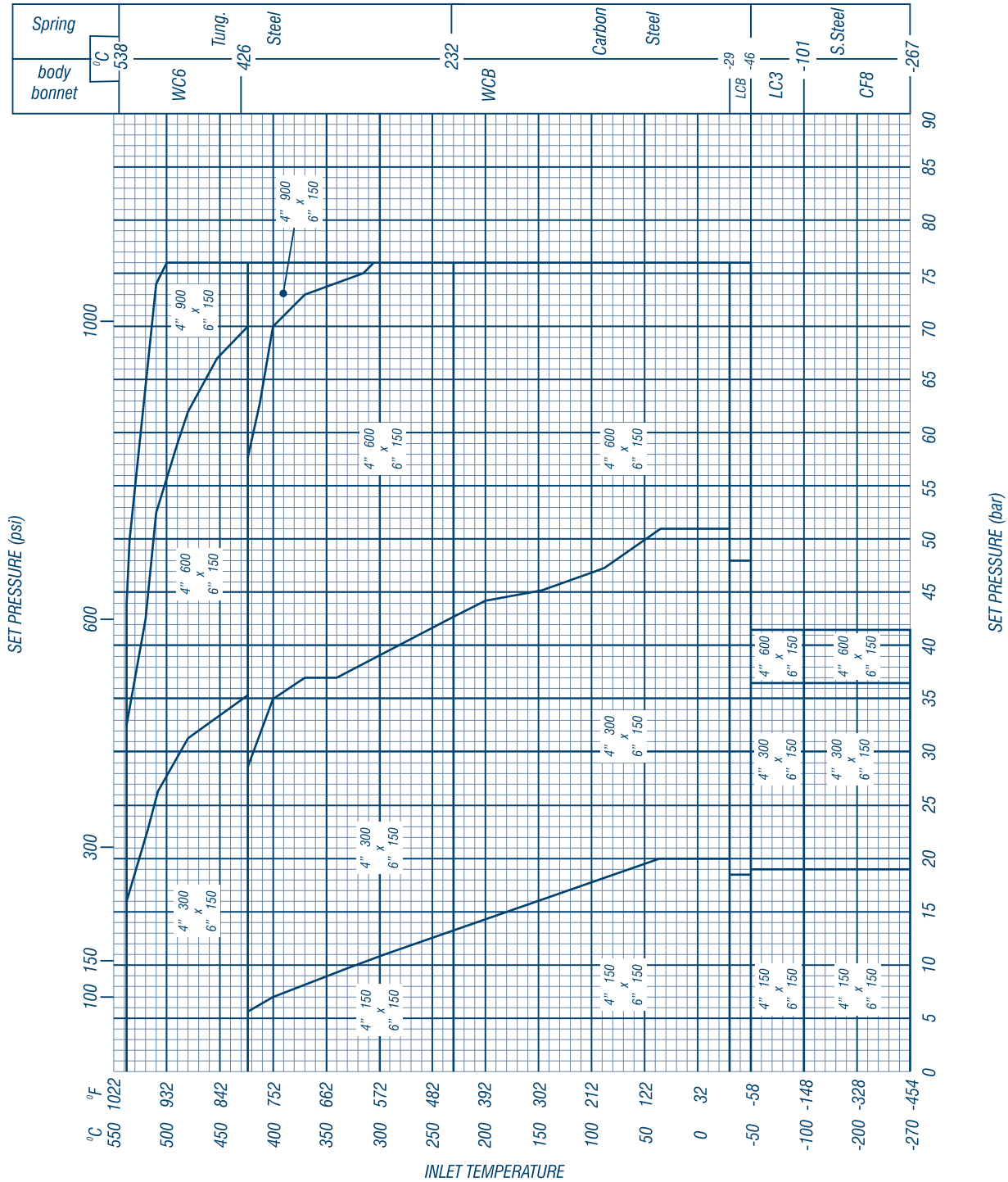



N	ORIFICE	$30,581 \text{ cm}^2$ $4,740 \text{ in}^2$
---	---------	---

SELECTION CHART
PRESSURE-TEMPERATURE LIMITS (ACCORDING TO ANSI B16.34 AND API 526)

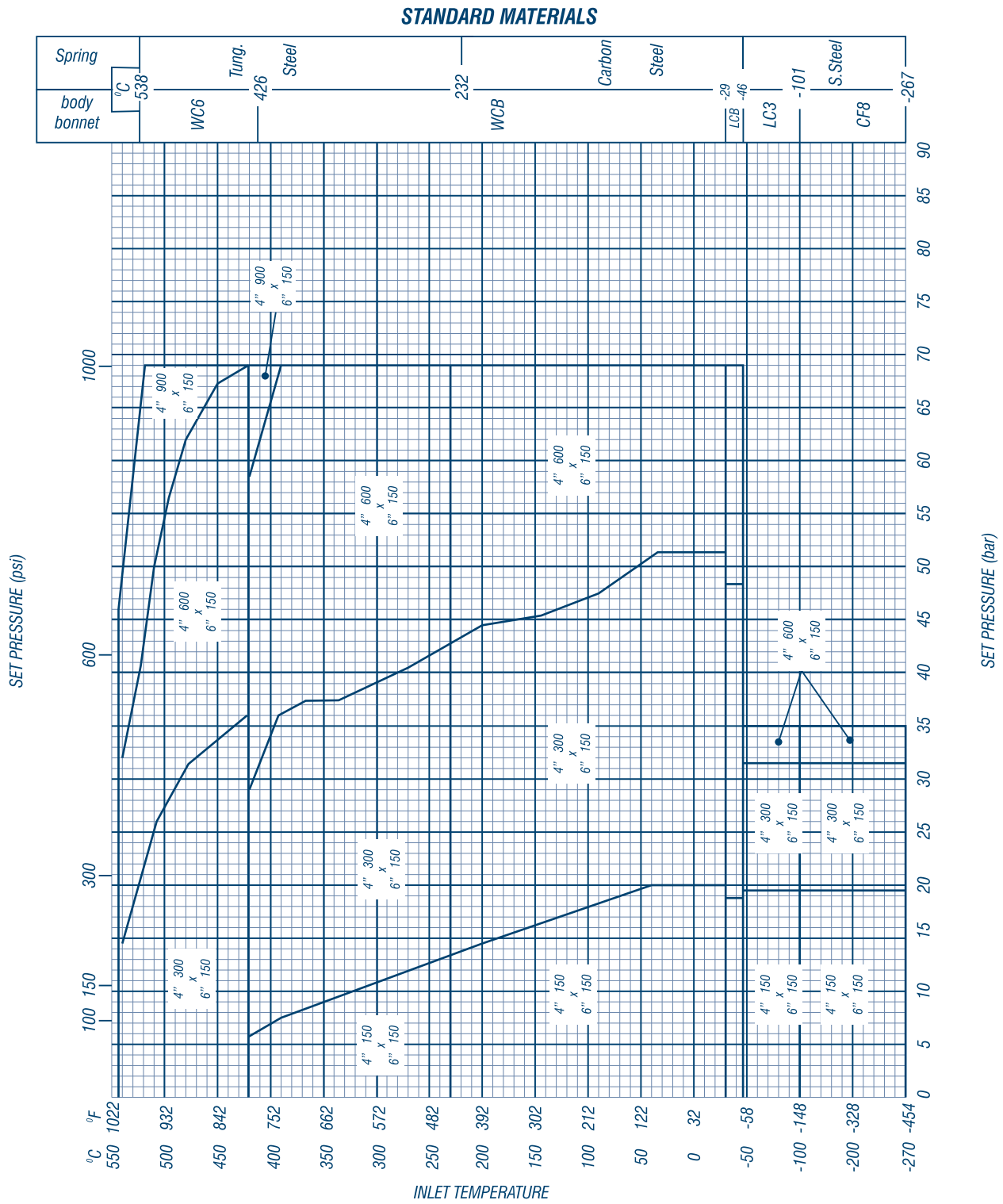



P	ORIFICE	45,007 cm² 6,976 in²
----------	----------------	---

SELECTION CHART
PRESSURE-TEMPERATURE LIMITS (ACCORDING TO ANSI B16.34 AND API 526)

STANDARD MATERIALS

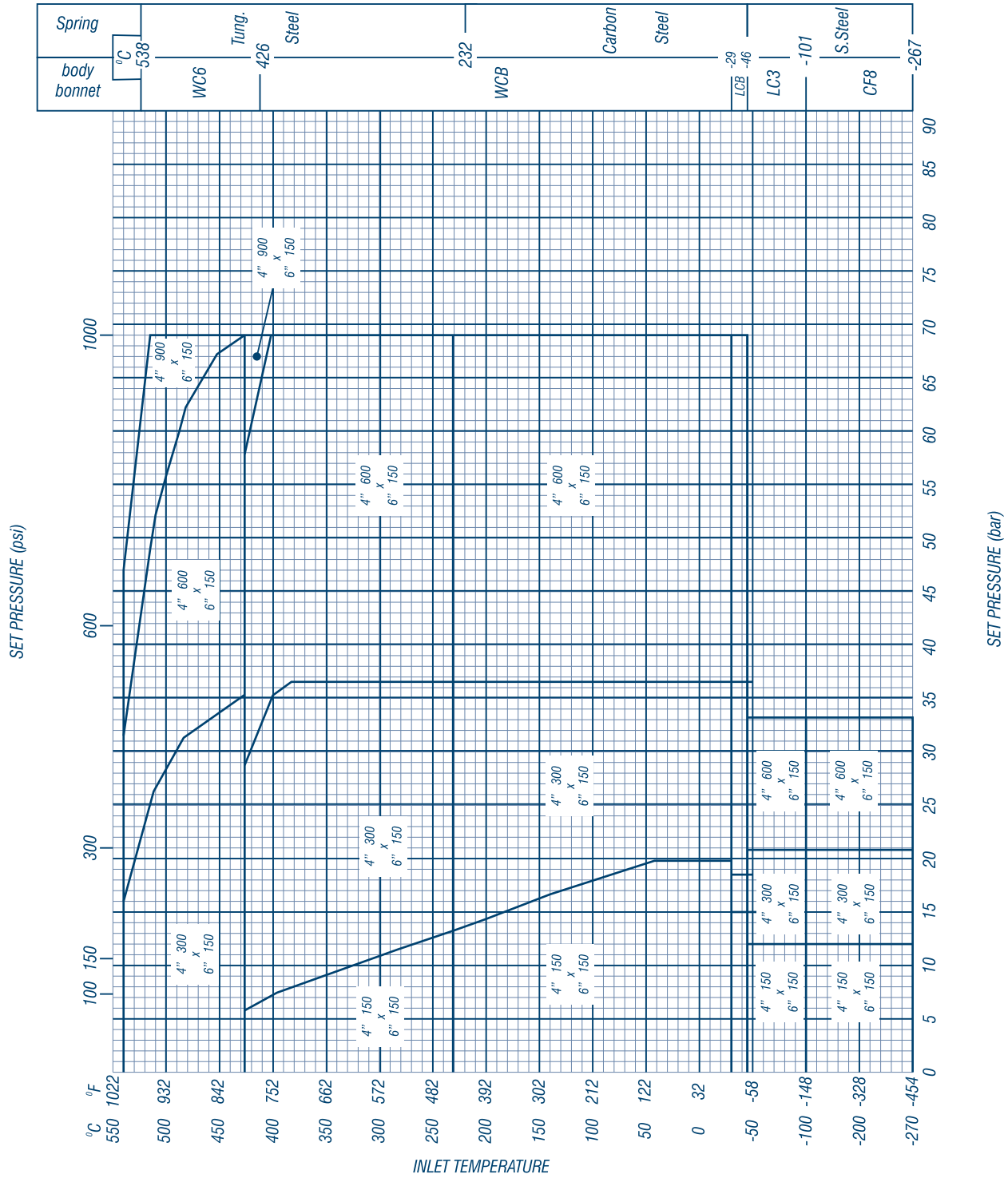



P₂	ORIFICE	63,617 cm² 9,861 in²
----------------------	----------------	---

SELECTION CHART
PRESSURE-TEMPERATURE LIMITS (ACCORDING TO ANSI B16.34 AND API 526)

STANDARD MATERIALS

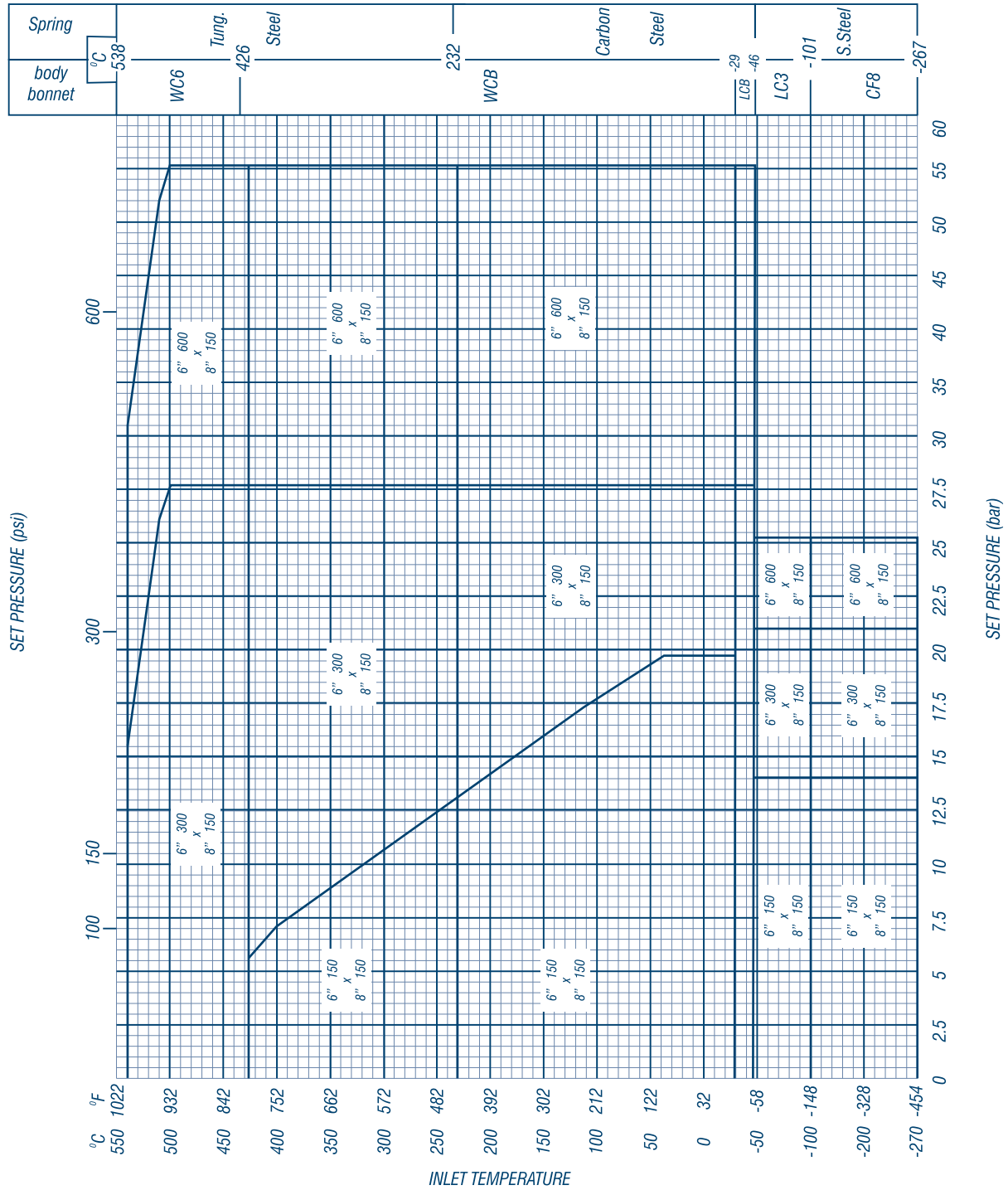



Q	ORIFICE	77,913 cm² 12,076 in²
---	---------	--

SELECTION CHART
PRESSURE-TEMPERATURE LIMITS (ACCORDING TO ANSI B16.34 AND API 526)

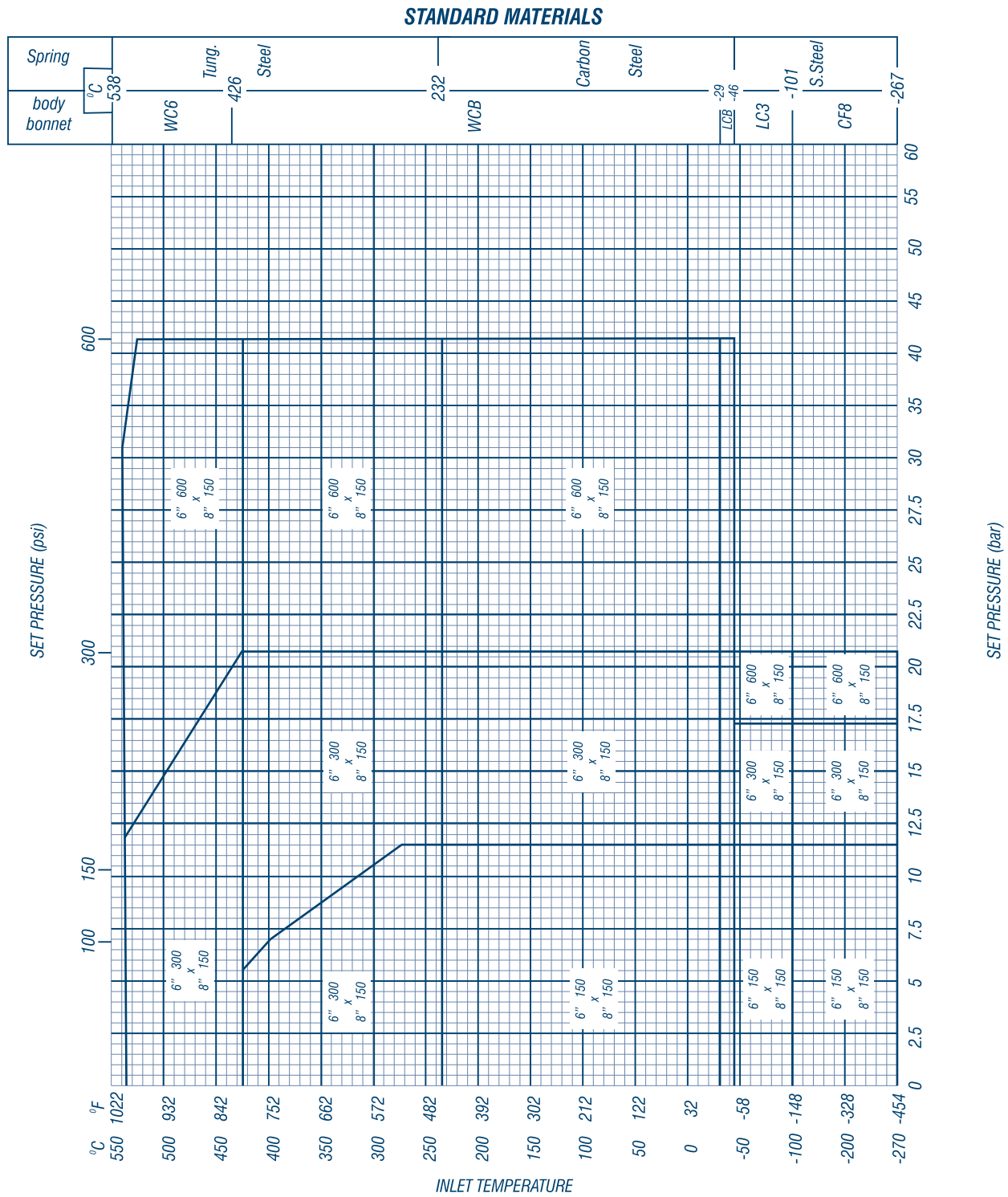



Q₂	ORIFICE	95,379 cm² 14,783 in²
----------------------	----------------	--

SELECTION CHART
PRESSURE-TEMPERATURE LIMITS (ACCORDING TO ANSI B16.34 AND API 526)

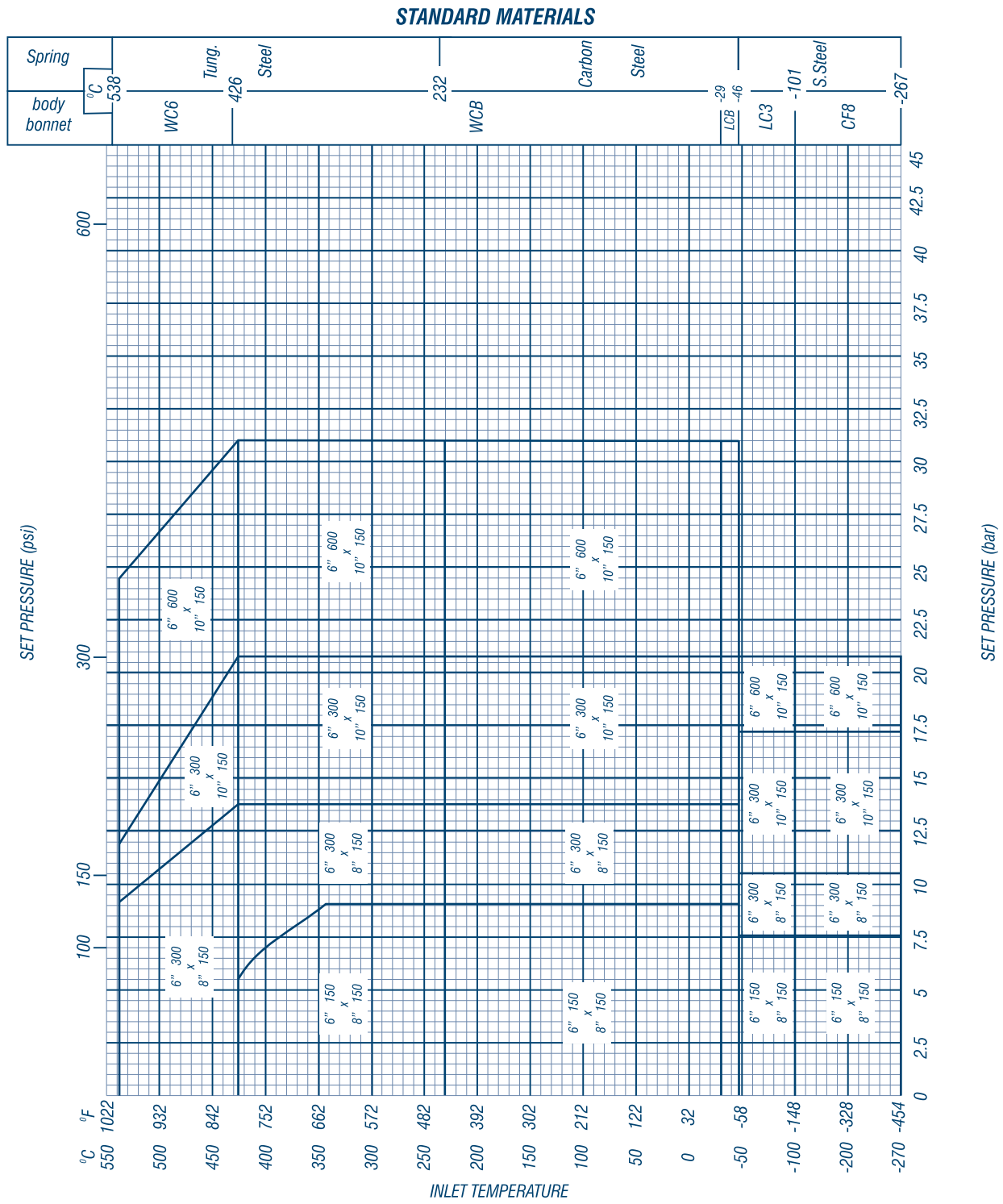



R	ORIFICE	112,663 cm² 17,462 in²
---	---------	---

SELECTION CHART
PRESSURE-TEMPERATURE LIMITS (ACCORDING TO ANSI B16.34 AND API 526)

STANDARD MATERIALS

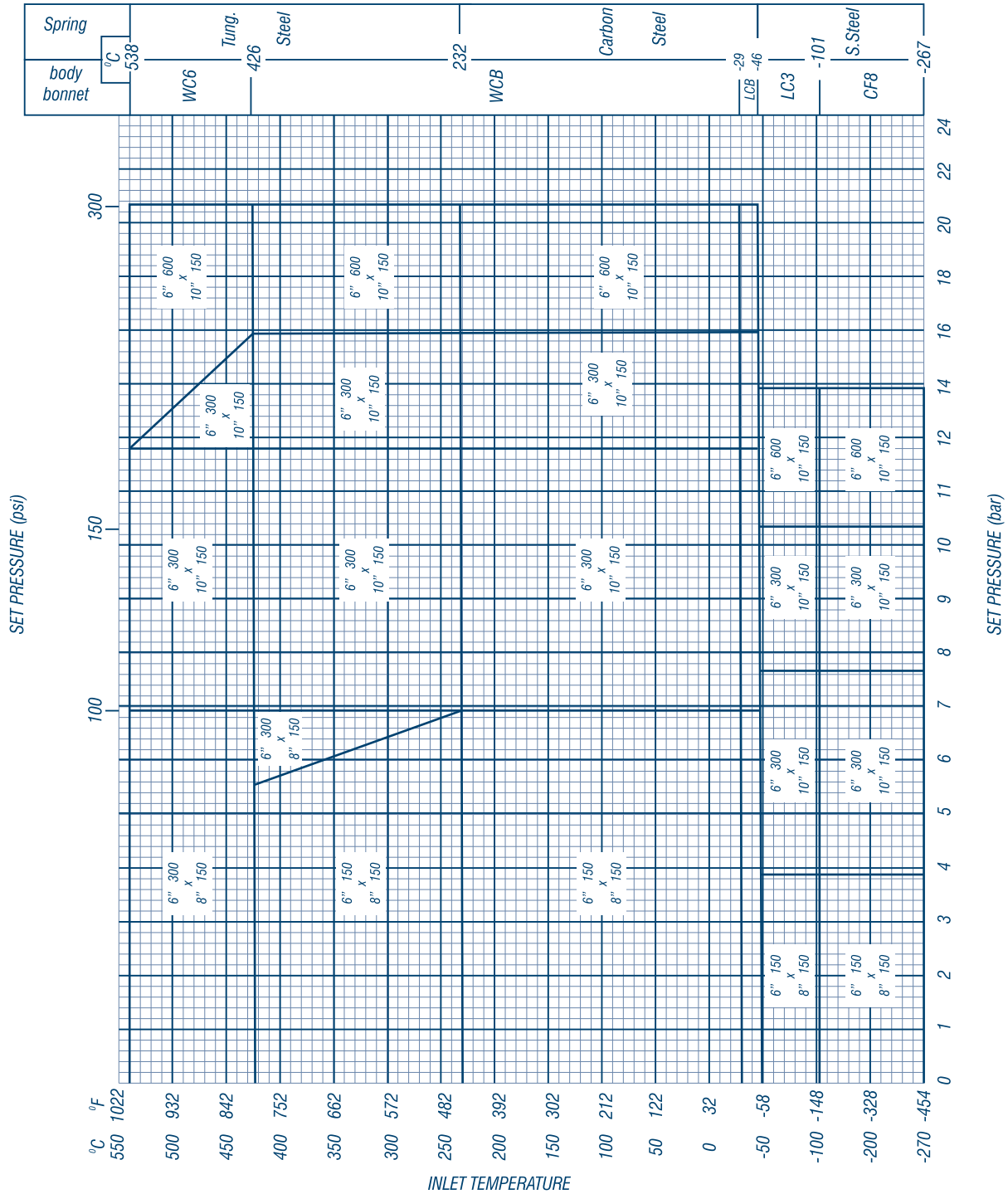



R ₂	ORIFICE	148,058 cm² 22,949 in²
----------------	---------	---

SELECTION CHART
PRESSURE-TEMPERATURE LIMITS (ACCORDING TO ANSI B16.34 AND API 526)

STANDARD MATERIALS

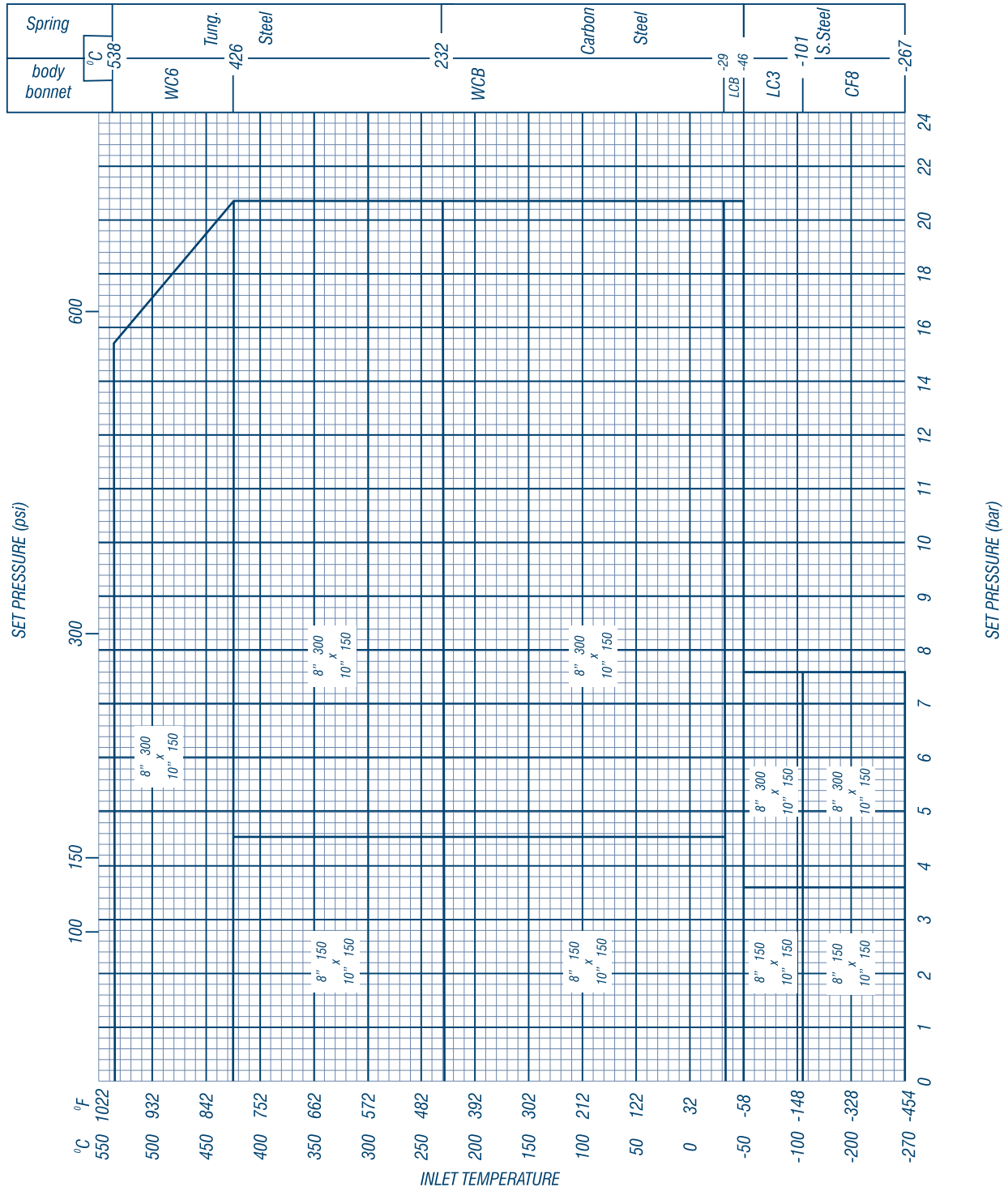



T	ORIFICE	183,281 cm² 28,408 in²
---	---------	---

SELECTION CHART
PRESSURE-TEMPERATURE LIMITS (ACCORDING TO ANSI B16.34 AND API 526)

STANDARD MATERIALS

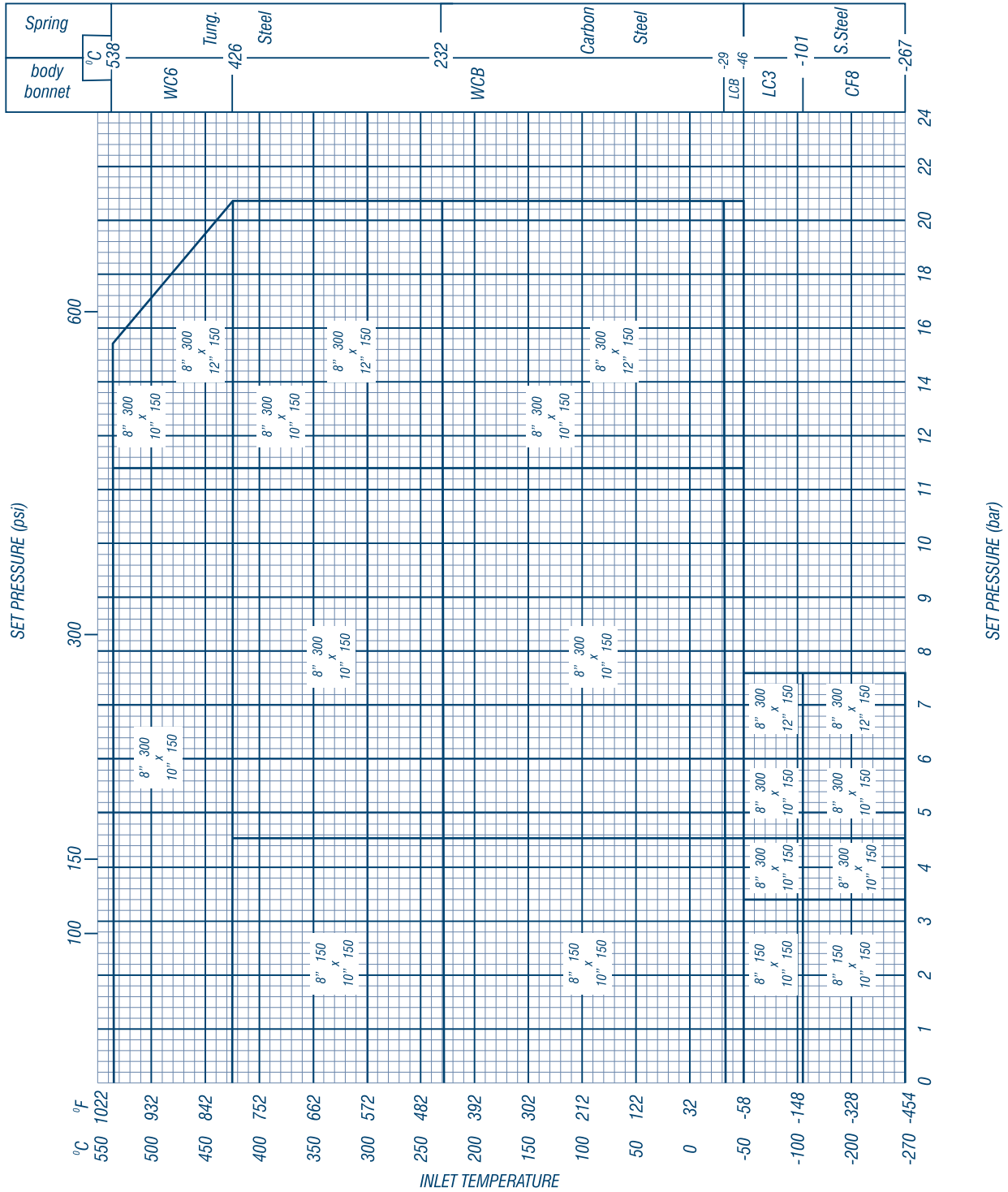

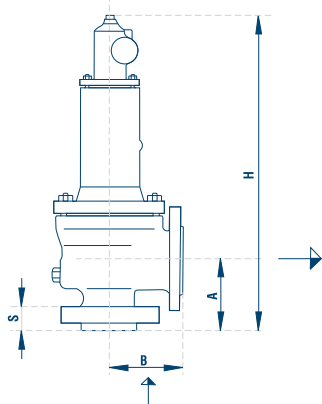

DIMENSIONS AND WEIGHTS

The dimensions and the weights are approximate. will not assume any liability for discrepancies between actual dimensions and weights and those shown in this table.

ORIF cm ² sq.in	SIZE Inlet x Outlet inch	RATING ASME	Dimensions				Approx. weight
			A	B	H	S	
			mm				
D 0,785 0,121	1x2	150X150	105	114	489	35	22
	1x2	300X150	105	114	489	35	22
	1x2	600X150	105	114	489	35	22
	1 1/2 x2	900X300	105	140	557	47	36
	1 1/2 x2	1500X300	105	140	557	47	36
	1 1/2 x3	2500X300	140	178	647	65	55
E 1,389 0,215	1x2	150X150	105	114	489	35	22
	1x2	300X150	105	114	489	35	22
	1x2	600X150	105	114	489	35	22
	1 1/2 x2	900X300	105	140	557	47	36
	1 1/2 x2	1500X300	105	140	557	47	36
	1 1/2 x3	2500X300	140	178	647	65	55
F 2,164 0,335	1 1/2 x2	150X150	124	121	508	40	24
	1 1/2 x2	300X150	124	121	508	40	25
	1 1/2 x2	600X150	124	121(a)	508	40	25
	1 1/2 x3	900X300	124	165	576	47	40
	1 1/2 x3	1500X300	124	165	576	47	40
	1 1/2 x3	2500X300	140	178	647	65	55
G 3,530 0,547	1 1/2 x3	150x150	124	121	508	40	27
	1 1/2 x3(*)	300/600x150	124	121	508	40	28
	1 1/2 x3	300x150	124	152	576	40	34
	1 1/2 x3	600x150	124	152	576	40	34
	1 1/2 x3	900x300	124	165	576	47	40
	2x3	1500x300	156	171	662	70	60
H 5,515 0,854	2x3	2500x300	156	171	662	70	60
	1 1/2 x3	150x150	130	124	582	40	34
	1 1/2 x3(*)	300/600x150	130	124	582	40	34
	2x3	300/600x150	137(a)	124	589	40	35
	2x3	600x150	154	162	662	56	50
	2x3	900x150	154	162	662	56	50
	2x3	1500x300	154(a)	171(a)	662	70	60



DIMENSIONS AND WEIGHTS

ORIF cm ² sq.in	SIZE InxOutlet inch.	RATING InxOutlet ANSI	DIMENSIONS				Approx. Weight kg
			A	B	H	S	
			mm				
J 9,079 1,407	2x3	150x150	137	124	589	42	36
	2x3	300x150	137	124	589	42	36
	3x4	600x150	156(a)	165(a)	717	48	66
	3x4	900x150	184	181	747	56	74
	3x4	600x150	184	181	747	56	75
	3x4	900x150	184	181	747	56	75
	3x4	1500x150	184	181	747	65	80
K 12,946 2,006	3x4	150x150	156	165	717	48	66
	3x4	300x150	156	165	717	48	66
	3x4	600x150	184	181	747	56	75
	3x4	900x150	184(a)	181(a)	747	56	75
	3x6	900x150	197	216	942	65	130
	3x6	1500x300	197	216	942	65	130
K2 16,619 2,575	3x4	150x150	156	165	717	48	66
	3x4	300x150	156	165	717	48	67
	3x4	600x150	184	181	747	56	75
	3x4	900x150	184	181	747	56	75
	3x6	900x150	197	216	942	65	130
	3x6	1500x300	197	216	942	65	130
L 20,109 3,116	3x4	150x150	156	165	717	48	66
	3x4	300x150	156	165	717	48	67
	4x6	300x150	178	184	920	54	120
	4x6	600x150	178	203	1017	60	165
	4x6	900x150	225(a)	254(a)	1067	65	184
	4x6	1500x150	225(a)	254(a)	1067	74	185
	4x6	150x150	178	184	920	54	120
M 25,339 3,927	4x6	300x150	178	184	920	54	120
	4x6	600x150	178	203	1017	60	168
	4x6	900x150	225(a)	254(a)	1067	65	185
	4x6	150x150	197	210	939	54	131
N 30,581 4,740	4x6	300x150	197	210	939	54	132
	4x6	600x150	225(a)	254(a)	1067	65	185
	4x6	900x150	225(a)	254(a)	1067	65	186
	4x6	150x150	181	229	923	46	125
P 45,007 5,976	4x6	300x150	181	229	923	54	130
	4x6	300x150	225	254	1067	65	181
	4x6	600x150	225	254	1067	65	186
	4x6	900x150	225	254	1067	65	187
	4x6	150x150	240	241	1112	57	220
P2 63,617 9,861	6x8	300x150	240	241	1112	57	225
	6x8	600x150	240	241	1112	68	230
	6x8	150x150	240	241	1112	57	220
Q 77,913 12,076	6x8	300x150	240	241	1112	57	225
	6x8	600x150	240	241	1112	68	230
	6x8	600x150	240	241	1147	68	245
	6x8	150x150	240	241	1112	57	220
Q2 95,379 14,783	6x8	300x150	240	241	1112	57	225
	6x10	300x150	240	267	1147	68	255
	6x10	600x150	240	267	1147	68	260
	6x8	150x150	240	241	1112	57	220
R 112,663 17,462	6x8	300x150	240	241	1112	57	225
	6x10	300x150	240	241	1112	68	240
	6x10	300x150	240	267	1147	68	255
	6x10	600x150	240	267	1147	68	260
	6x10	150x150	275	279	1292	61	350
R2 148,058 22,949	8x10	300x150	275	279	1292	61	350
	8x10	150x100	275	279	1292	61	350
T 183,281 28,408	8x10	300x100	275	279	1292	61	350
	8x10	300x100	275	279	1417	61	370
	8x10	300x150	275	279	1417	61	380
	8x12	300x150	275	279	1417	61	380



DEFINITIONS (abstract from EN ISO 4126-1)

Lift

The actual travel of the valve disc away from the closed position.

Flow area

The minimum cross-sectional flow area (but not the curtain area) between inlet and seat which is used to calculate the theoretical flow capacity, with no deduction for any obstruction.

Coefficient of discharge

The value of actual flowing capacity (from tests) divided by the theoretical flowing capacity (from calculation).

Built-up back pressure

The pressure existing at the outlet of a safety valve caused by flow through the valve and the discharge system.

Superimposed back pressure

The pressure existing at the outlet of a safety valve at the time when the device is required to operate. It is the result of pressure in the discharge system from other sources.

Certified (discharge) capacity

That portion of the measured capacity permitted to be used as a basis for the application of a safety valve. It may, for example, equal to the theoretical capacity times the coefficient of discharge times the derating factor.

Cold differential test pressure

The inlet static pressure at which a safety valve is set to commence to open on the test stand.

This test pressure includes corrections for service conditions, for example, back pressure and/or temperature.

Reseating pressure (of a safety valve)

The value of the inlet static pressure at which the disc re-establishes contact with the seat or at which the lift becomes zero.

Relieving pressure

The pressure used for the sizing of a safety valve which is \geq set pressure + overpressure.

Set pressure

The predetermined pressure at which a safety valve under operating conditions commences to open. It is the gauge pressure measured at the valve inlet at which the pressure forces tending to open the valve for the specific service conditions are in equilibrium with the forces retaining the valve disc on its seat.

Blowdown (of a safety valve)

The difference between set and re-seating pressures, normally stated as a percentage of set pressure except for pressures of less than 3 bar when the blowdown is expressed in bar.

Overpressure (of a safety valve)

A pressure increase over the set pressure, at which the safety valve attains the lift specified by the manufacturer, usually expressed as a percentage of the set pressure. This is the overpressure used to certify the safety valve.



DISCHARGING COEFFICIENTS CERTIFIED SINCE 1976

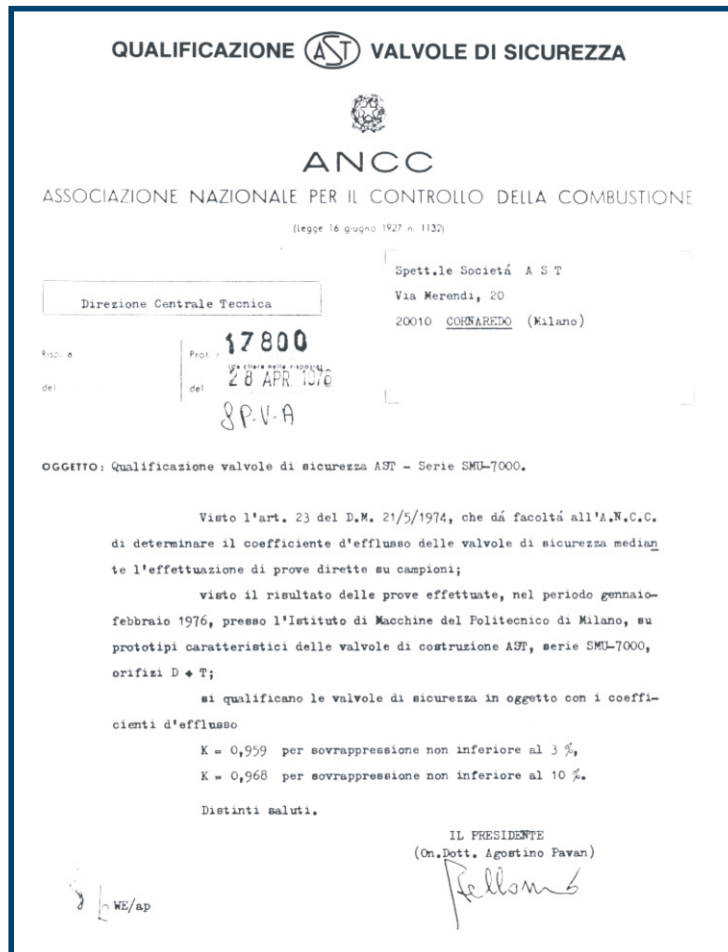

Safety & Control Valves
Manufactured under AST SpA licence - (SMU-7000, SMFN-7000, SU-7000).



AST SpA products distributed by
UNI KLINGER LIMITED Safety & Control Valves division - SMS-7100, Pilot operated valve, Control valve.

In view of technical progress designs and dimensions are subject to change without notice.

Manufactured by:

UKL® UNI KLINGER LIMITED
- Safety Valve & Control Valve Division

Sales Office : SC1, 5th Fl., Kohinoor Estate. Mumbai-Pune Highway, Khadki, Pune-411003.
Tel.: 91-20-41023000 Fax: (020) 41023001
e-mail: salescso@uniklinger.com Website: www.uniklinger.com

Factory : (SV & CV Division) : Plot No. 56, Gat No. 156,1544, 168,169,170 & 171,
Village - Sanaswadi, Tal. - Shirur, Pune - 412 208. India.
Mob: +91 093267 39844 E mail: astworks@uniklinger.com

Branch Offices :

Baroda :
102, Offtel Towers II,
1st Floor,
R.C. Dutt Road,
Baroda- 390 005.
Tel.: 91-265-2312343/2340660
Fax : 91-265-2341419
e-mail :
salesbar@uniklinger.com

Chennai :
East Coast Centre,
5th Floor, 553, Mount Rd.,
Teyanampet,
Chennai- 600 018.
Tel.: 91-44-24345707
Fax :91-44 -24343960.
e-mail :
saleschen@uniklinger.com

Kolkata :
9, 'CHITRAKOOT',
8th Floor, 230 A,
AJC Bose Road,
Kolkata- 700 020.
Tel.: 91-33-22872510
Fax: 91-33-22876494
e-mail :
salescal@uniklinger.com

Mumbai:
22, 2nd Flr., Shreeji Arcade
Comm. Premises CHS,
Almeda Rd., Thane-400 602
Tel. :91-22-25421140
91-22-25440461
Fax :91-22-25440463
e-mail :
salesmum@uniklinger.com

New Delhi:
321, Ansal Chamber-II,
6, Bhikaji Cama Place,
New Delhi-110 066.
Tel.: 91-11-41658767
91-11-26193847
Fax: 91-11-41658768
e-mail :
salesdel@uniklinger.com

Pune:
Sc1, 5th Fl., Kohinoor Est.
Mumbai-Pune Highway,
Khadki, Pune-411003
Tel. : 91-20-25811606
: 91-20-32500229
Fax : 91-20-25824643
e-mail :
salespune@uniklinger.com